

# LE25S81A



ON Semiconductor®

www.onsemi.com

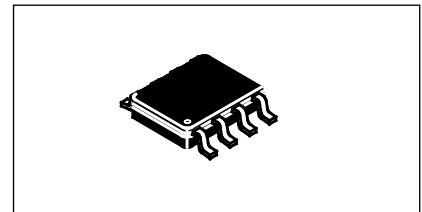
Advance Information

## 8M-bit (1024K x 8) Serial Flash Memory

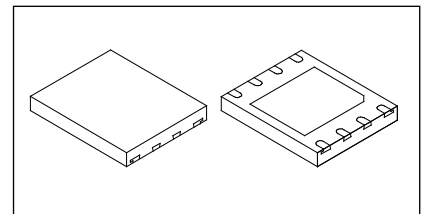
### 1. Overview

The LE25S81A is a SPI bus flash memory device with a 8M bit (1024K × 8-bit) configuration. It uses a single power supply. While making the most of the features inherent to a serial flash memory device, the LE25S81A is housed in an 8-pin ultra-miniature package. All these features make this device ideally suited to storing program in applications such as portable information devices, which are required to have increasingly more compact dimensions.

The LE25S81A also has a small sector erase capability which makes the device ideal for storing parameters or data that have fewer rewrite cycles and conventional EEPROMs cannot handle due to insufficient capacity.



VSOIC8 NB



VDFN8 5x6, 1.27P / VSON8T (6x5)

### 2. Features

- Operations power supply : 1.65 to 2.40V supply voltage range
- Operating frequency : 70MHz (max)
- Temperature range : -40 to +90°C
- Serial interface : SPI mode 0, mode 3 supported
- Electronic Identification : JDEC ID, Device ID, Serial Flash Discoverable Parameter (SFDP)
- Sector size : 4K bytes/small sector, 64K bytes/sector
- Erase functions : small sector erase(SSE), sector erase(SE), chip erase(CHE)
- Page program function : 256 bytes/page
- Status functions : Ready/Busy information, protect information
- Low operation current : 5.0mA (Low-power program mode, typ), 3.0mA(Low-Power Read mode, typ)
- Erase time : 10ms(SSE, typ), 15ms(SE, typ), 120ms(CHE, typ)
- Page program time (tPP) : 0.3ms/256 bytes (typ), 0.5ms/256 bytes (max)
- Emergency shutdown of the current consumption
  - : transition to a standby state in less than 20us from the active by Write Suspend
  - : transition to a standby state in less than 40us from the active by Software Reset
- High reliability : 100,000 erase/program cycles  
: 20 years data retention period
- Package : LE25S81AMD SOIC8, 150 mils CASE 751BD-01  
: LE25S81AFD VSOIC8 NB CASE 753AA  
: LE25S81AQE VSON8T (6.0 × 5.0) CASE 509AG  
: KGD N/A

\* This product is licensed from Silicon Storage Technology, Inc. (USA).

This document contains information on a new product. Specifications and information herein are subject to change without notice.

### ORDERING INFORMATION

See detailed ordering and shipping information on page 53 of this data sheet.

# LE25S81A

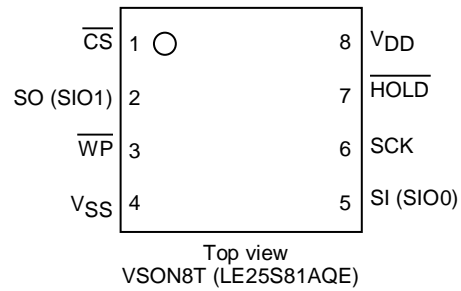
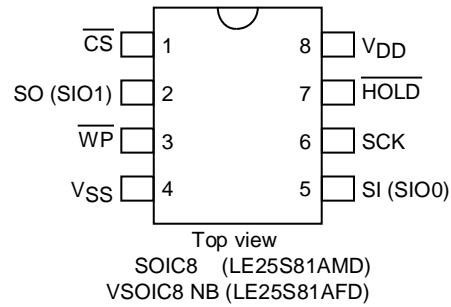
## 3. Specifications

**Absolute Maximum Ratings** at  $T_a = 25^\circ\text{C}$

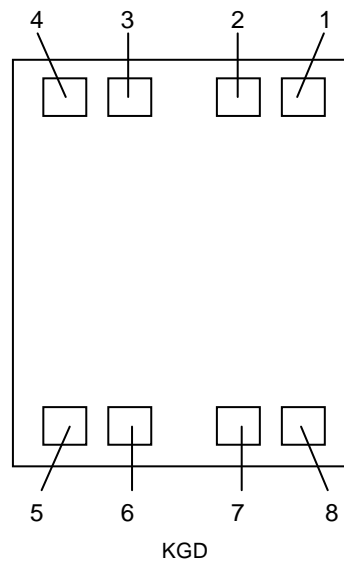
| Parameter           | Symbol    | Conditions | Ratings              | Unit             |
|---------------------|-----------|------------|----------------------|------------------|
| Supply voltage      |           |            | -0.5 to +2.9         | V                |
| DC input voltage    |           |            | -0.5 to $V_{DD}+0.5$ | V                |
| Over-shoot voltage  |           |            | -1.0 to $V_{DD}+1.0$ | V                |
| Storage temperature | $T_{stg}$ |            | -55 to +150          | $^\circ\text{C}$ |

Stresses exceeding those listed in the Maximum Ratings table may damage the device. If any of these limits are exceeded, device functionality should not be assumed, damage may occur and reliability may be affected.

## 4. Package Types and Pin Configurations



| Pad No. | Name                     |
|---------|--------------------------|
| 1       | $\overline{\text{CS}}$   |
| 2       | SO (SIO1)                |
| 3       | $\overline{\text{WP}}$   |
| 4       | $V_{SS}$                 |
| 5       | SI (SIO0)                |
| 6       | SCK                      |
| 7       | $\overline{\text{HOLD}}$ |
| 8       | $V_{DD}$                 |



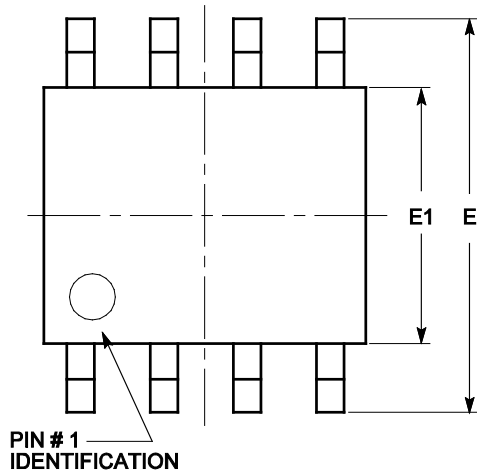
# LE25S81A

## Package Dimensions

unit : mm

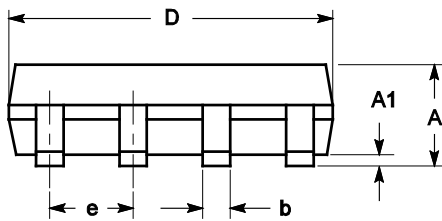
LE25S81AMDTWG

**SOIC 8, 150 mils**  
**CASE 751BD-01**  
**ISSUE O**

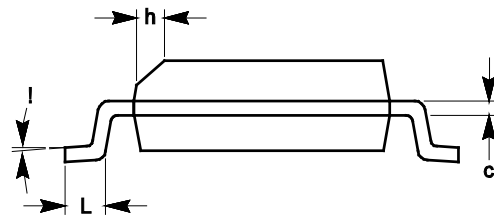


**TOP VIEW**

| SYMBOL | MIN      | NOM | MAX  |
|--------|----------|-----|------|
| A      | 1.35     |     | 1.75 |
| A1     | 0.10     |     | 0.25 |
| b      | 0.33     |     | 0.51 |
| c      | 0.19     |     | 0.25 |
| D      | 4.80     |     | 5.00 |
| E      | 5.80     |     | 6.20 |
| E1     | 3.80     |     | 4.00 |
| e      | 1.27 BSC |     |      |
| h      | 0.25     |     | 0.50 |
| L      | 0.40     |     | 1.27 |
| !      | 0%       |     | 8%   |



**SIDE VIEW**



**END VIEW**

**Notes:**

- (1) All dimensions are in millimeters. Angles in degrees.
- (2) Complies with JEDEC MS-012.



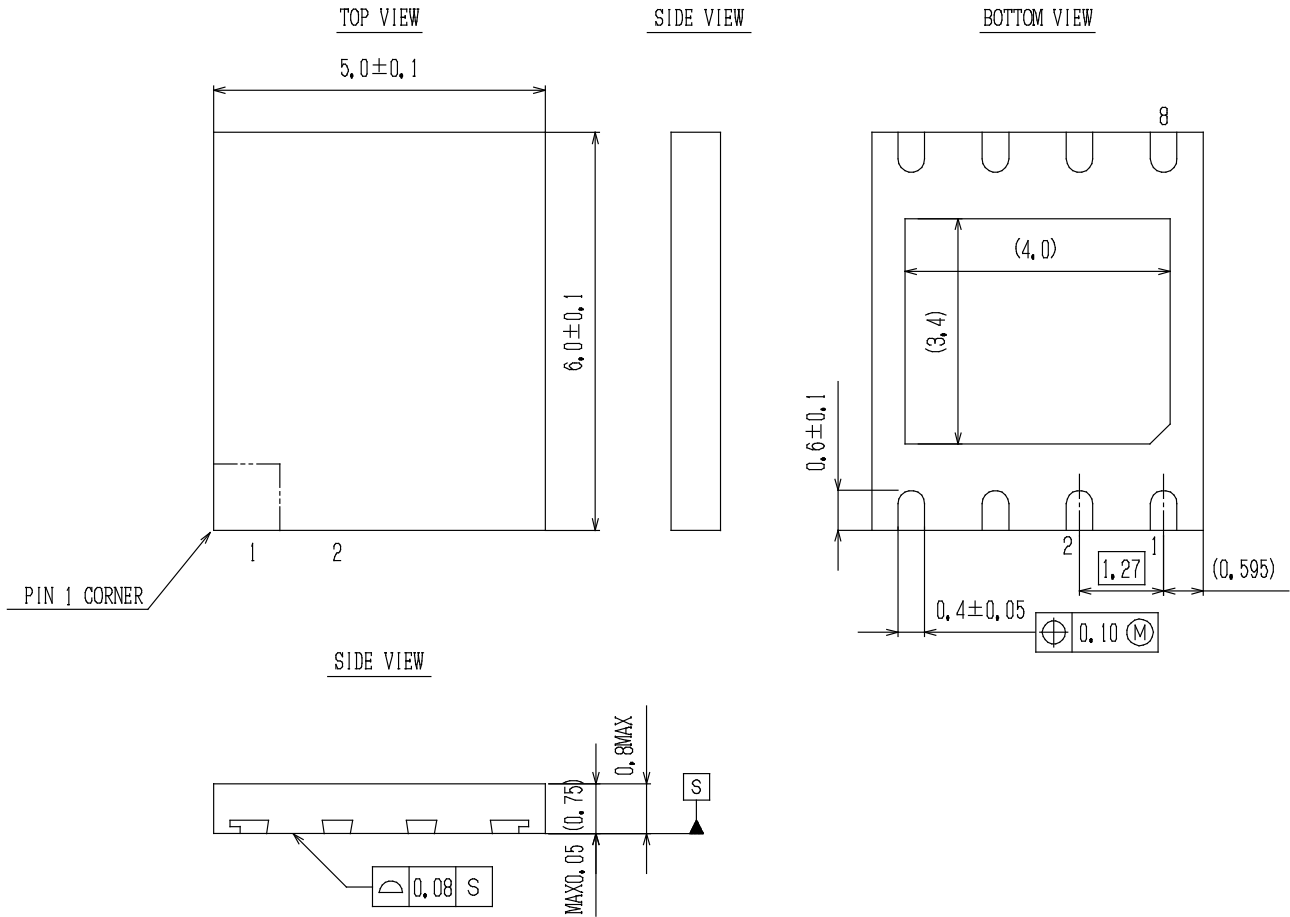
# LE25S81A

## Package Dimensions

unit : mm

LE25S81AQE

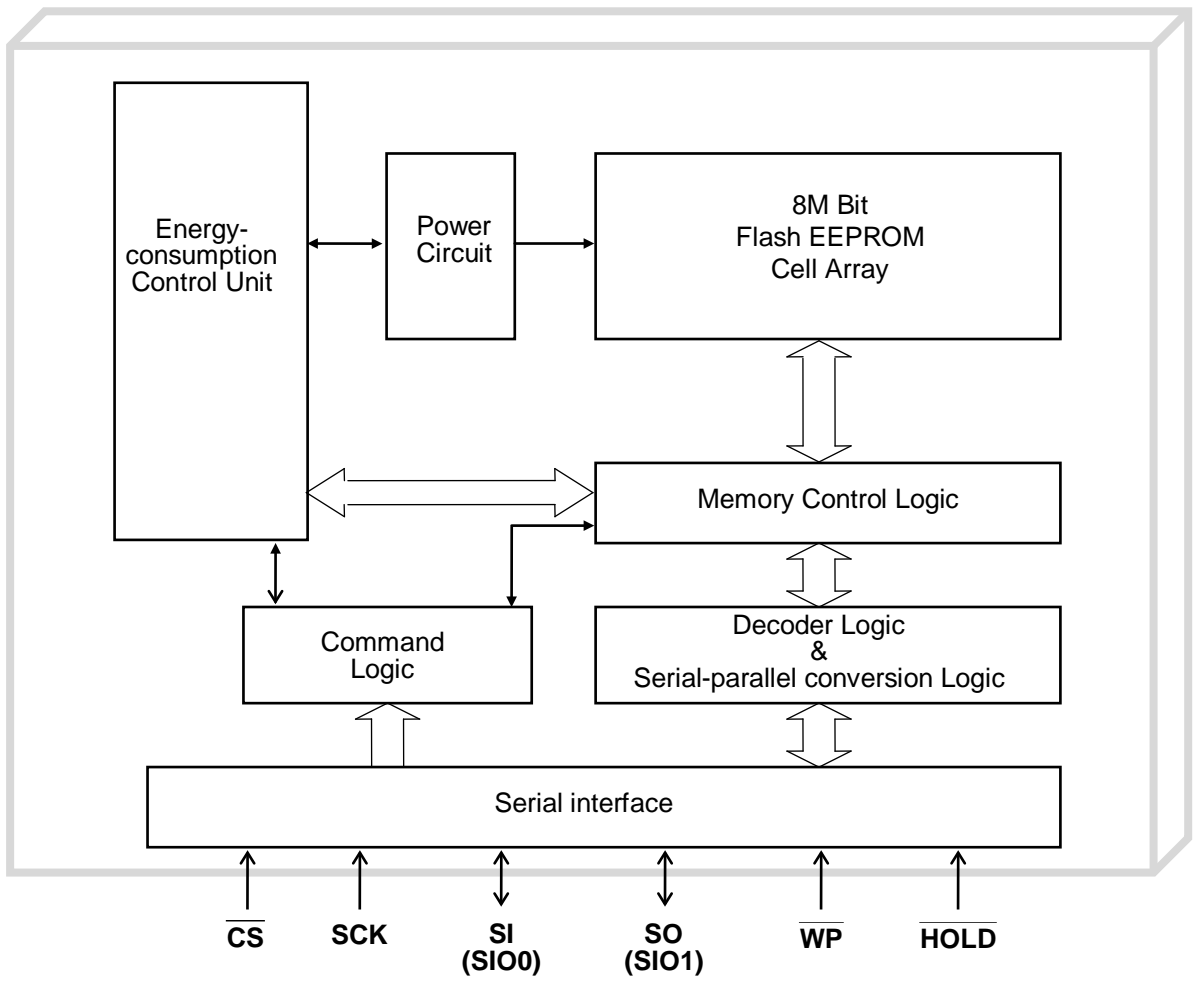
**VDFN8 5x6, 1.27P / VSON8T (6x5)**  
**CASE 509AG**  
**ISSUE O**



## 5. Pin Description

| Symbol                   | Pin Name   | IO  | Description   |
|--------------------------|--|-----|---|
| $\overline{\text{CS}}$   | Chip select                                      | I   | The device becomes active when the logic level of this pin is low; it is deselected and placed in standby status when the logic level of the pin is high.   |
| SCK                      | Serial clock                                     | I   | This pin controls the data input/output timing.<br>The input data and addresses are latched synchronized to the rising edge of the serial clock, and the data is output synchronized to the falling edge of the serial clock. |
| SI<br>(SIO0)             | Serial data input<br>(Serial data input output)  | I/O | The data and addresses are input from this pin, and latched internally synchronized to the rising edge of the serial clock.<br>(It changes into input/output pin during the Dual operation.)                                  |
| SO<br>(SIO1)             | Serial data output<br>(Serial data input output) | I/O | The data stored inside the device is output from this pin synchronized to the falling edge of the serial clock.<br>( It changes into input/output pin during the Dual operation.)   |
| $\overline{\text{WP}}$   | Write protect                                    | I   | The Write Status Register Protect (SRWP) takes effect when the logic level of this pin is low.  |
| $\overline{\text{HOLD}}$ | Hold   | I   | Serial communication is suspended when the logic level of this pin is low.  |
| NC                       | No Connection                                    |     |   |
| V <sub>DD</sub>          | Power supply                                     |     | This pin supplies the 1.65 to 2.40V supply voltage.   |
| V <sub>SS</sub>          | Ground   |     | This pin supplies the 0V supply voltage.  |

6. Block Diagram



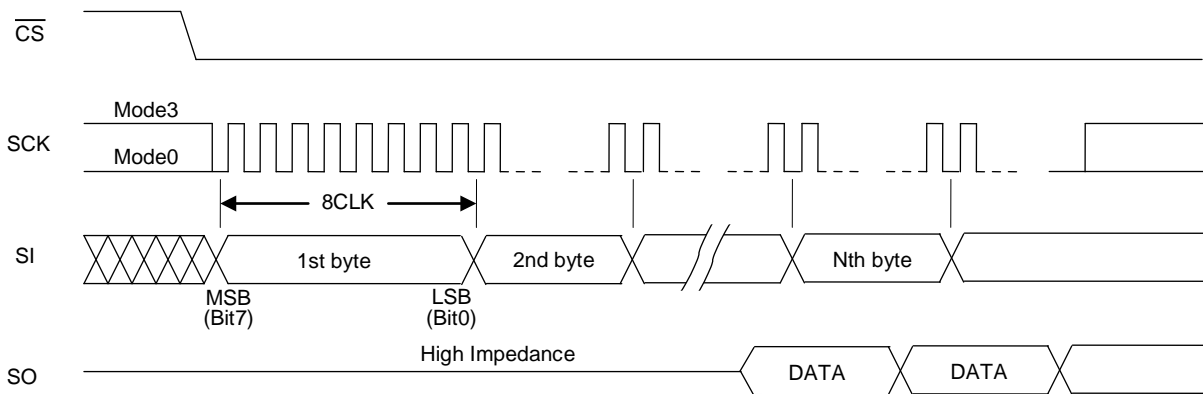
## 7. Device Operation

### 7-1. Standard SPI Modes

The read, erase, program and other required functions of the device are executed through the command registers. The serial I/O corrugate is shown in "Figure 1. SPI Modes" and the command list are shown in "Table.1-1. Command Settings (Standard SPI)". At the falling  $\overline{CS}$  edge the device is selected, and serial input is enabled for the commands, addresses, etc. These inputs are normalized in 8 bit units and taken into the device interior in synchronization with the rising edge of SCK, which causes the device to execute operation according to the command that is input.

The LE25S81A supports both serial interface SPI mode 0 and SPI mode 3. At the falling  $\overline{CS}$  edge, SPI mode 0 is automatically selected if the logic level of SCK is low, and SPI mode 3 is automatically selected if the logic level of SCK is high.

Figure 1. SPI Modes



### 7-2. Dual SPI Modes

The LE25S81A supports Dual SPI operations when using "Dual Output Read (RDDO: 3Bh)", "Dual I/O Read (RDIO: BBh)". The SI and SO pins change into the input/output pin (SIOx) during the Dual SPI modes. The command list is shown in "Table.1-2. Command Settings (Dual SPI)".

Pin Configurations at Dual SPI Mode

| Standard SPI |   | Dual SPI |
|--------------|---|----------|
| SI           | → | SIO0     |
| SO           | → | SIO1     |



# LE25S81A

**Table 1-1. Command Settings (Standard SPI)**

| Command | Description<br>(clock number)            | 1st byte<br>(0 - 7) | 2nd byte<br>(8 - 15) | 3rd byte<br>(16- 23) | 4th byte<br>(24 - 31) | 5th byte<br>(32 - 39) | 6th byte<br>(40 - 47) | Nth byte<br>(8N-8 to 8N-1) |
|---------|--|---------------------|----------------------|----------------------|-----------------------|-----------------------|-----------------------|----------------------------|
| WREN    | Write enable                             | 06h                 |                      |                      |                       |                       |                       |                            |
| WRDI    | Write disable                            | 04h                 |                      |                      |                       |                       |                       |                            |
| RDSR    | Read Status Register                     | 05h                 |                      |                      |                       |                       |                       |                            |
| WRSR    | Write Status Register                    | 01h                 | DATA                 |                      |                       |                       |                       |                            |
| RDLP    | Low -Power Read<br>(Max: 40MHz)          | 03h                 | A23-A16              | A15-A8               | A7-A0                 | RD <sup>(5)</sup>     | RD <sup>(5)</sup>     | RD <sup>(5)</sup>          |
| RDHS    | High-Speed Read<br>(Max: 70MHz)          | 0Bh                 | A23-A16              | A15-A8               | A7-A0                 | X                     | RD <sup>(5)</sup>     | RD <sup>(5)</sup>          |
| SSE     | Small Sector Erase (4KB)                 | 20h / D7h           | A23-A16              | A15-A8               | A7-A0                 |                       |                       |                            |
| SE      | Sector Erase (64KB)                      | D8h                 | A23-A16              | A15-A8               | A7-A0                 |                       |                       |                            |
| CHE     | Chip Erase (8M bits)                     | 60h / C7h           |                      |                      |                       |                       |                       |                            |
| PP      | Normal Page Program                      | 02h                 | A23-A16              | A15-A8               | A7-A0                 | PD <sup>(7)</sup>     | PD <sup>(7)</sup>     | PD <sup>(7)</sup>          |
| PPL     | Low-Power Page Program                   | 0Ah                 |                      |                      |                       |                       |                       |                            |
| WSUS    | Write Suspend                            | B0h                 |                      |                      |                       |                       |                       |                            |
| RESM    | Resume                                   | 30h                 |                      |                      |                       |                       |                       |                            |
| RJID    | Read JEDEC ID                            | 9Fh                 | Manufacture<br>(62h) | Memory<br>Type (16h) | Capacity<br>(14h)     |                       |                       |                            |
| RID     | Read Device ID<br>(Exit power down mode) | ABh                 | X                    | X                    | X                     | Device ID<br>(87h)    |                       |                            |
| RSFDP   | Read SFDP<br>(Max: 70MHz)                | 5Ah                 | A23-A16              | A15-A8               | A7-A0                 | X                     | RD <sup>(5)</sup>     | RD <sup>(5)</sup>          |
| DP      | Deep Power down                          | B9h                 |                      |                      |                       |                       |                       |                            |
| EDP     | Exit Deep<br>Power down                  | ABh                 |                      |                      |                       |                       |                       |                            |
| RSTEN   | Reset Enable                             | 66h                 |                      |                      |                       |                       |                       |                            |
| RST     | Reset                                    | 99h                 |                      |                      |                       |                       |                       |                            |

**Table 1-2. Command Settings (Dual SPI) --- Max: 66MHz**

| Command | Description<br>(clock number) | 1st byte<br>(0 - 7) | 2nd byte<br>(8 - 15)  | 3rd byte<br>(16- 23)           | 4th byte<br>(24 - 31) | 5th byte<br>(32 - 39) | 6th byte<br>(40 - 47) | Nth byte<br>(8N-8 to 8N-1) |
|---------|-------------------------------|---------------------|-----------------------|--------------------------------|-----------------------|-----------------------|-----------------------|----------------------------|
| RDDO    | Dual Output Read              | <b>3Bh</b>          | A23-A16               | A15-A8                         | A7-A0                 | Z                     | RDD <sup>(6)</sup>    | RDD <sup>(6)</sup>         |
| RDIO    | Dual I/O Read                 | <b>BBh</b>          | A23-A8 <sup>(6)</sup> | A7-A0 <sup>(6)</sup> ,<br>X, Z | RDD <sup>(6)</sup>    | RDD <sup>(6)</sup>    | RDD <sup>(6)</sup>    | RDD <sup>(6)</sup>         |

**Note:**

- "X" signifies "don't care" (that is to say, any value may be input).
- "Z" signifies "high-impedance".
- The "h" following each code indicates that the number given is in hexadecimal notation.
- Addresses A23 to A20 for all commands are "Don't care".
- "RD" Read data on SO.
- "RDD" Dual Read data:  
SIO0=(Bit6, Bit4, Bit2, Bit0)  
SIO1=(Bit7, Bit5, Bit3, Bit1)
- "PD" Page Program data on SO.
- Dual SPI address input from SIO0 and SIO1:  
SIO0=(A22, A20, A18, A16, A14, A12, A10, A8, A6, A4, A2, A0)  
SIO1=(A23, A21, A19, A17, A15, A13, A11, A9, A7, A5, A3, A1)

8. Memory Organization

Table 2. Memory Organization

8M Bits

| Sector<br>(64KB)<br>Symbol :SE | small sector<br>(4KB)<br>Symbol :SSE | address space<br>(A23 to A0) |          |
|--------------------------------|--------------------------------------|------------------------------|----------|
| 15                             | SSE[255]                             | 0FF000h                      | 0FFFFFFh |
|                                | to                                   |                              |          |
| 14 to 6                        | SSE[240]                             | 0F0000h                      | 0F0FFFh  |
|                                | SSE[239]                             | 0EF000h                      | 0EFFFFh  |
| 5                              | to                                   |                              |          |
|                                | SSE[96]                              | 060000h                      | 060FFFh  |
| 4                              | SSE[95]                              | 05F000h                      | 05FFFFh  |
|                                | to                                   |                              |          |
| 3                              | SSE[80]                              | 050000h                      | 050FFFh  |
|                                | SSE[79]                              | 04F000h                      | 04FFFFh  |
| 2                              | to                                   |                              |          |
|                                | SSE[64]                              | 040000h                      | 040FFFh  |
| 1                              | SSE[63]                              | 03F000h                      | 03FFFFh  |
|                                | to                                   |                              |          |
| 0                              | SSE[48]                              | 030000h                      | 030FFFh  |
|                                | SSE[47]                              | 02F000h                      | 02FFFFh  |
| 0                              | to                                   |                              |          |
|                                | SSE[32]                              | 020000h                      | 020FFFh  |
| 0                              | SSE[31]                              | 01F000h                      | 01FFFFh  |
|                                | to                                   |                              |          |
| 0                              | SSE[16]                              | 010000h                      | 010FFFh  |
|                                | SSE[15]                              | 00F000h                      | 00FFFFh  |
| 0                              | to                                   |                              |          |
|                                | SSE[4]                               | 004000h                      | 004FFFh  |
| 0                              | SSE[3]                               | 003800h                      | 003FFFh  |
|                                |                                      | 003000h                      | 0037FFh  |
| 0                              | SSE[2]                               | 002800h                      | 002FFFh  |
|                                |                                      | 002000h                      | 0027FFh  |
| 0                              | SSE[1]                               | 001800h                      | 001FFFh  |
|                                |                                      | 001000h                      | 0017FFh  |
| 0                              | SSE[0]                               | 000800h                      | 000FFFh  |
|                                |                                      | 000000h                      | 0007FFh  |

## 9. Status Registers

The status registers hold the operating and setting statuses inside the device, and this information can be read by Read Status Register (RDSR) and the protect information can be rewritten by Write Status Register (WRSR). There are 8 bits in total, and "Table 3. Status registers" gives the significance of each bit.

**Table 3. Status Registers**

| Bit  | Name                    | Logic | Function   | Power-on Time Information |
|------|-------------------------|-------|--|---------------------------|
| Bit0 | $\overline{\text{RDY}}$ | 0     | Ready  | 0                         |
|      |                         | 1     | Erase/Program                                      |                           |
| Bit1 | WEN                     | 0     | Write disabled                                     | 0                         |
|      |                         | 1     | Write enabled                                      |                           |
| Bit2 | BP0                     | 0     | Block protect information<br>Protected area switch | Nonvolatile information   |
|      |                         | 1     |  |                           |
| Bit3 | BP1                     | 0     |  |                           |
|      |                         | 1     |  |                           |
| Bit4 | BP2                     | 0     |  |                           |
|      |                         | 1     |  |                           |
| Bit5 | TB                      | 0     | Block protect                                      | Nonvolatile information   |
|      |                         | 1     | Upper side/Lower side switch                       |                           |
| Bit6 | SUS                     | 0     | Erase/Program is not suspended                     | 0                         |
|      |                         | 1     | Erase/Program suspended                            |                           |
| Bit7 | SRWP                    | 0     | Write Status Register enabled                      | Nonvolatile information   |
|      |                         | 1     | Write Status Register disabled                     |                           |

Note: All non-volatile bits of the status registers-1 are set "0" in the factory.

## 9-1. Contents of each status register

### 9-1-1. $\overline{\text{RDY}}$ (bit 0)

The  $\overline{\text{RDY}}$  register is for detecting the write (Program, Erase and Write Status Register) end. When it is "1", the device is in a busy state, and when it is "0", it means that write is completed.

### 9-1-2. WEN (bit 1)

The WEN register is for detecting whether the device can perform write operations. If it is set to "0", the device will not perform the write operation even if the write command is input. If it is set to "1", the device can perform write operations in any area that is not block-protected.

WEN can be controlled using the write enable (WREN) and write disable (WRDI). By inputting the write enable (WREN: 06h), WEN can be set to "1" by inputting the write disable (WRDI: 04h), it can be set to "0." In the following states, WEN is automatically set to "0" in order to protect against unintentional writing.

- At power-on
- Upon completion of Erase (SSE, SE, or CHE)
- Upon completion of Page Program (PP or PPL)
- Upon completion of Write Status Register (WRSR)

\* If a write operation has not been performed inside the LE25S81A because, for instance, the command input for any of the write operations (SSE, SE, CHE, PP, PPL or WRSR) has failed or a write operation has been performed for a protected address, WEN will retain the status established prior to the issue of the command concerned. Furthermore, its state will not be changed by a read operation.

### 9-1-3. BP0, BP1, BP2, TB (bits 2, 3, 4, 5)

Block Protect: BP0, BP1, BP2 and TB are status register bits that can be rewritten, and the memory space to be protected can be set depending on these bits. For the setting conditions, refer to "[Table 4. Protected Level Setting Conditions](#)".

BP0, BP1, and BP2 are used to select the protected area and TB to allocate the protected area to the higher-order address area or lower-order address area.

**Table 4. Protection Level Setting Conditions**

| Protected Level | Protected Block           | Status Register Bits |     |     |     | Protected Area   |
|-----------------|---------------------------|----------------------|-----|-----|-----|------------------|
|                 |                           | TB                   | BP2 | BP1 | BP0 |                  |
| 0               | Whole area unprotected    | X                    | 0   | 0   | 0   | None             |
| T1              | Upper side 1/16 protected | 0                    | 0   | 0   | 1   | F0000h to FFFFFh |
| T2              | Upper side 1/8 protected  | 0                    | 0   | 1   | 0   | E0000h to FFFFFh |
| T3              | Upper side 1/4 protected  | 0                    | 0   | 1   | 1   | C0000h to FFFFFh |
| T4              | Upper side 1/2 protected  | 0                    | 1   | 0   | 0   | 80000h to FFFFFh |
| B1              | Lower side 1/16 protected | 1                    | 0   | 0   | 1   | 00000h to 0FFFFh |
| B2              | Lower side 1/8 protected  | 1                    | 0   | 1   | 0   | 00000h to 1FFFFh |
| B3              | Lower side 1/4 protected  | 1                    | 0   | 1   | 1   | 00000h to 3FFFFh |
| B4              | Lower side 1/2 protected  | 1                    | 1   | 0   | 0   | 00000h to 7FFFFh |
| 5               | Whole area protected      | X                    | 1   | 0   | 1   | 00000h to FFFFFh |
| 5               | Whole area protected      | X                    | 1   | 1   | X   | 00000h to FFFFFh |

Note: Chip Erase is enabled only when the protection level is 0.

**9-1-4. SUS (bit 6)**

The SUS register indicates when Erase/Program operation has been suspended. The SUS becomes "1" when the Erase/Program operation has been suspended (WSUS: B0h). The SUS is cleared to "0" by Resume (RESM:30h) or re-erase/program (SSE, SE, CHE, PP, PPL).

**9-1-5. SRWP (bit 7)**

Write Status Register protect SRWP is the bit for protecting the status registers, and its information can be rewritten. When SRWP is "1" and the logic level of the  $\overline{\text{WP}}$  pin is low, the Write Status Register (WRSR: 01h) is ignored, and status registers BP0, BP1, BP2, TB and SRWP are protected. When the logic level of the  $\overline{\text{WP}}$  pin is high, the status registers are not protected regardless of the SRWP state. The SRWP setting conditions are shown in "[Table 5. SRWP Setting Conditions](#)".

**Table 5. SRWP Setting Conditions**

| $\overline{\text{WP}}$ Pin | SRWP | Status Register Protect State |
|----------------------------|------|-------------------------------|
| 0                          | 0    | Unprotected                   |
|                            | 1    | Protected                     |
| 1                          | 0    | Unprotected                   |
|                            | 1    | Unprotected                   |

## 10. Description of Commands and Operations

A detailed description of the functions and operations corresponding to each command is presented below.

### 10-1. Read Status Register (RDSR)

The contents of the status registers can be read using the Read Status Register (RDSR). This command can be executed even during the following operations.

- Erase (SSE, SE or CHE)
- Page Program (PP or PPL)
- Write Status Register (WRSR)

"Figure 2. Read Status Register (RDSR)" shows the timing waveforms.

The sequence of RDSR operation :

CS goes to low → input RDSR command (05h)

→ Status Register data (SRWP, SUS, TB, BP2, BP1, BP0, WEN, RDY) out on SO →→

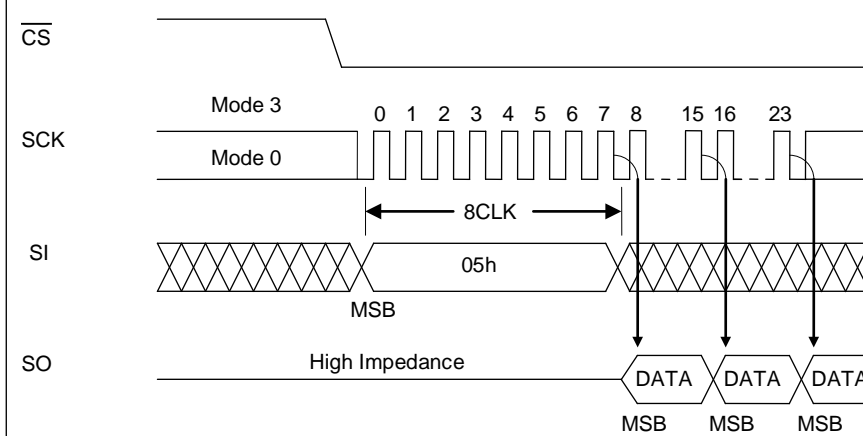
→ completed by CS=high

\* The data output starts from the falling edge of SCK(7th clock)

This command outputs the contents of the status registers synchronized to the falling edge of the clock (SCK).

If the clock input is continued after bit0 (RDY) has been output, the data is output by returning to bit7 (SRWP) that was first output, after which the output is repeated for as long as the clock input is continued. The data can be read by this command at any time (even during a program, erase cycle). By setting CS to high, the device is deselected, and Read JEDEC ID cycle is completed. While the device is deselected, the output pin SO is in a high-impedance state

**Figure 2. Read Status Register (RDSR)**



- DATA: Status Register, "[Table 3 Status Register](#)"

**10-2. Write Status Register (WRSR)**

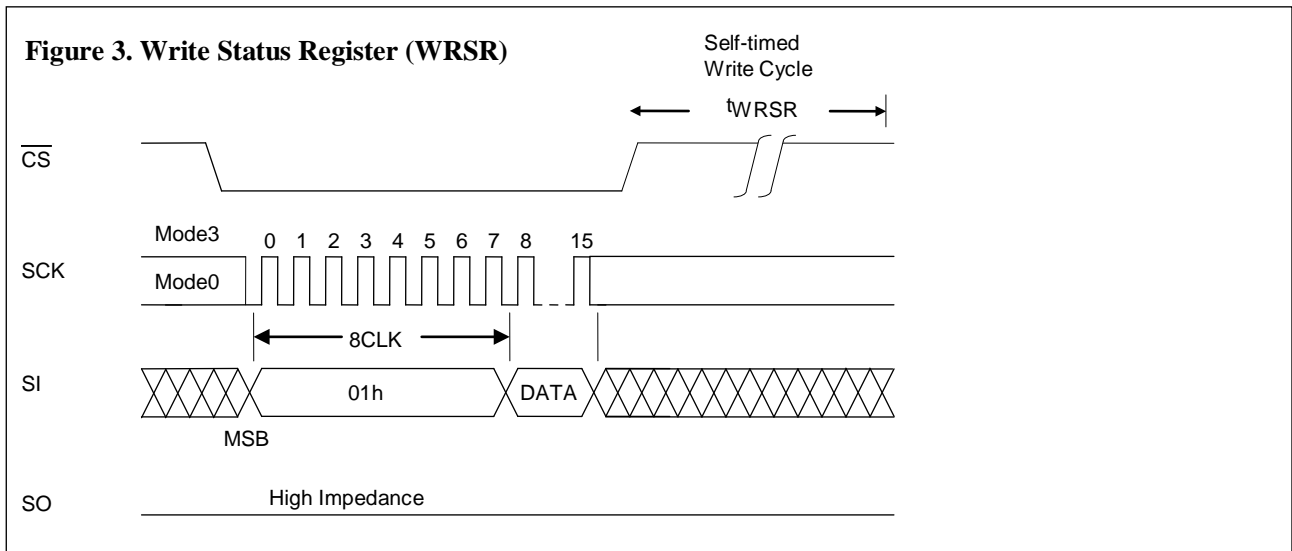
The information in status registers BP0, BP1, BP2, TB and SRWP can be rewritten using this command. bit0 ( $\overline{\text{RDY}}$ ), bit1 ( $\overline{\text{WEN}}$ ) and bit6 (SUS) are read-only bits and cannot be rewritten. The information in bits BP0, BP1, BP2, TB and SRWP is stored in the non-volatile memory, and when it is written in these bits, the contents are retained even at power-down.

"Figure 3. Write Status Register (WRSR)" shows the timing waveforms.

"Figure 31. Write Status Register Flowcharts" shows the flowcharts.

The sequence of WRSR operation :  
 CS goes to low → input WRSR command (01h)  
 → Status Register data input on SI  
 → CS goes to high (be executed by the rising  $\overline{\text{CS}}$  edge)

Erase and program are performed automatically inside the device by Write Status Register. So that erasing or other processing is unnecessary before executing the command. By the operation of this command, the information in bits BP0, BP1, BP2, TB and SRWP can be rewritten. Since bits bit0 ( $\overline{\text{RDY}}$ ), bit1 ( $\overline{\text{WEN}}$ ), bit 6 (SUS) of the status register cannot be written, no problem will arise if an attempt is made to set them to any value when rewriting the status register. Write Status Register ends can be detected by  $\overline{\text{RDY}}$  of Read Status Register (RDSR). To initiate Write Status Register, the logic level of the WP pin must be set high and status register  $\overline{\text{WEN}}$  must be set to "1".



**10-3. Write Enable (WREN)**

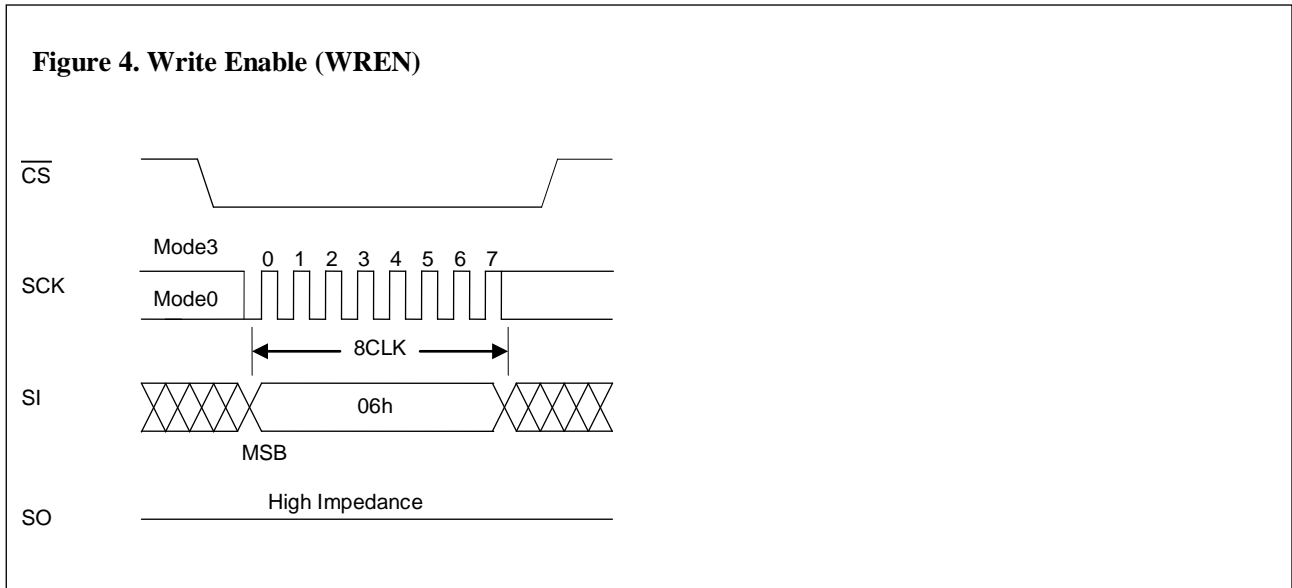
Before performing any of the operations listed below, the device must be placed in the write enable state.

- Erase (SSE, SE, CHE or CHE)
- Page Program (PP or PPL)
- Write Status Register (WRSR)

Operation is the same as for setting status register WEN to "1", and the state is enabled by this command.

"Figure 4. Write Enable (WREN)" shows the timing waveforms.

The sequence of WREN operation :  
 CS goes to low → input WREN command (06h)  
 → CS goes to high (be executed by the rising CS edge)



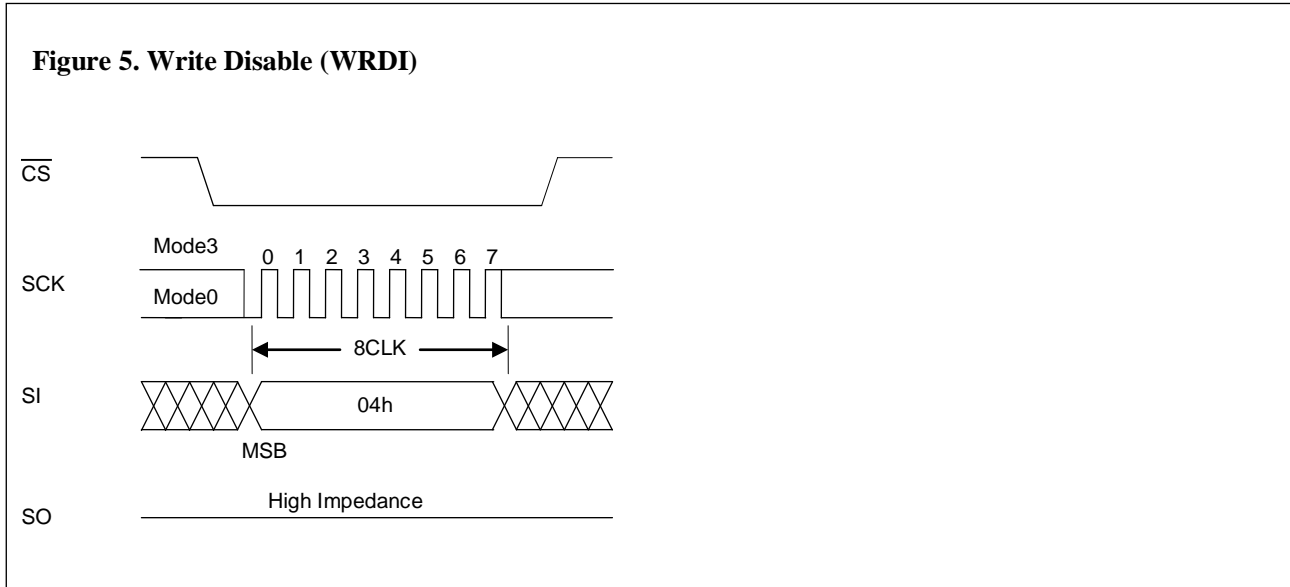


**10-4. Write Disable (WRDI)**

This command sets status register WEN to "0" to prohibit unintentional writing. The write disable state (WEN "0") is exited by setting WEN to "1" using the write enable (WREN: 06h).

"Figure 5. Write Disable (WRDI)" shows the timing waveforms.

The sequence of WRDI operation :  
 CS goes to low → input WRDI command (04h)  
 → CS goes to high (be executed by the rising CS edge)



**Standard SPI Read**

There are two Read commands, "Low-Power Read (RDLP: 03h)" and "High-Speed Read (RDHS: 0Bh)".

**10-5. Standard SPI Read**

There are two Read commands, Low-Power Read (RDLP) and High-Speed Read (RDHS).

**10-5-1. Low-Power Read command (RDLP) \_\_\_\_\_ Maximum Clock frequency: 40MHz**

This command is for reading data out.

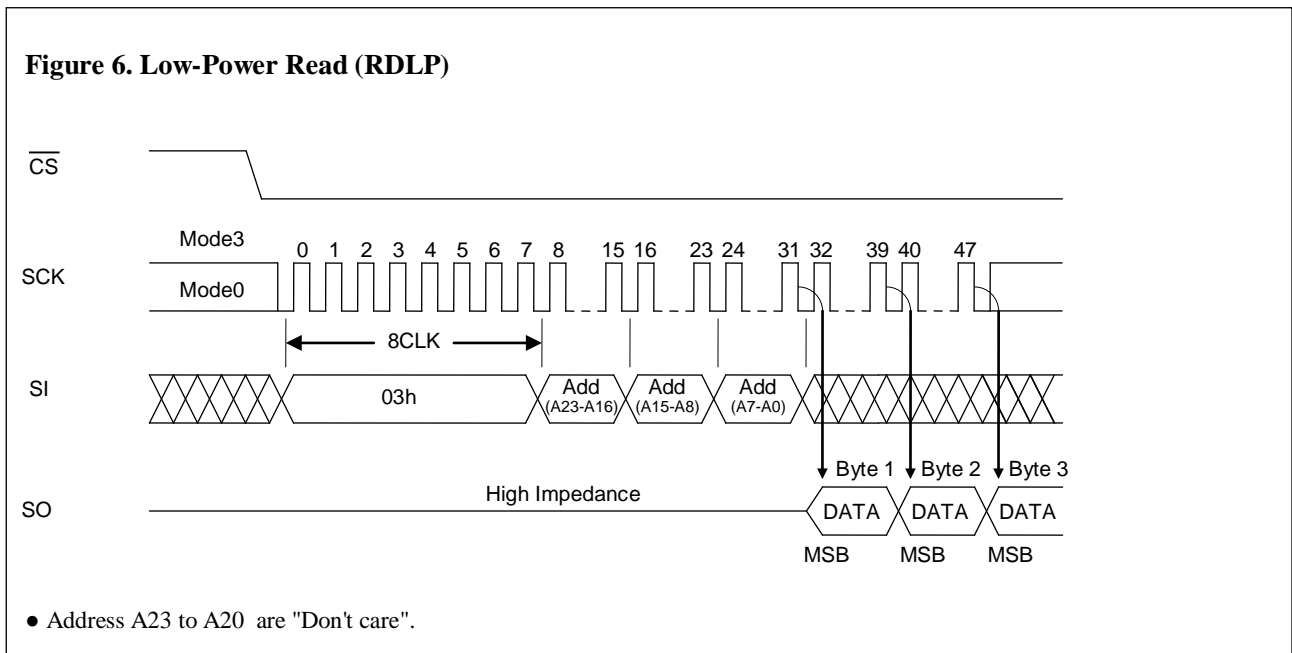
"Figure 6. Low-Power Read (RDLP)" shows the timing waveforms.

The sequence of RDLP operation :

- CS goes to low → input RDLP command (03h) → 3 Byte address (A23-A0) input on SI
- the corresponding data out on SO
- continuous data out (n-byte) →→
- completed by CS=high

\* The data output starts from the falling edge of SCK(31th clock)

The Address is latched on rising edge of SCK, and the corresponding data is shifted out on SO by the falling edge of SCK. The address is automatically incremented to the next higher address after each byte data is shifted out. If the SCK input is continued after the internal address arrives at the highest address (0FFFFFFh), the internal address returns to the lowest address (000000h). By setting CS to high, the device is deselected, and the read cycle is completed. While the device is deselected, the output pin SO is in a high-impedance state.



10-5-2. High-Speed Read command (RDHS) \_\_\_\_\_ Maximum Clock frequency: 70MHz

This command is for reading data out at the high frequency operation.

"Figure 7. High-Speed Read (RDHS)" shows the timing waveforms.

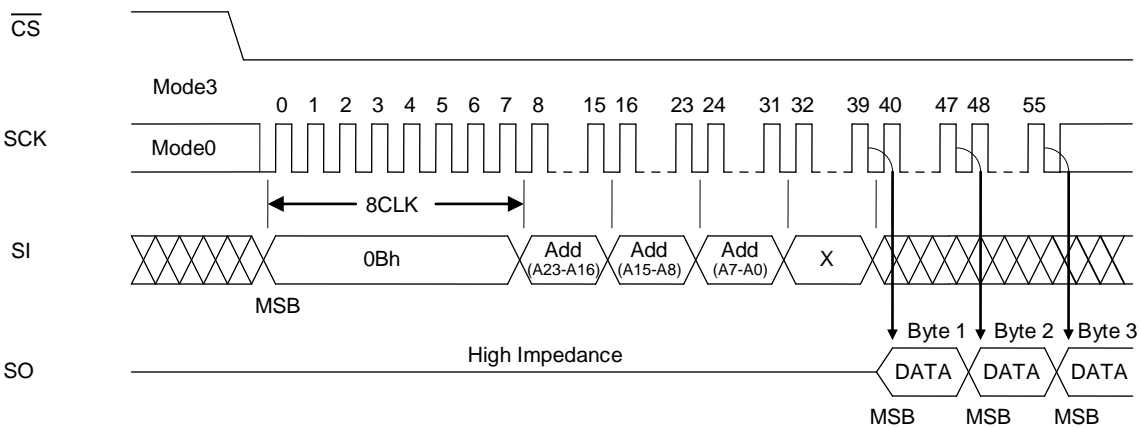
The sequence of RDHS operation :

- CS goes to low → input RDHS command (0Bh) → 3 Byte address (A23-A0) input on SI
- 1 byte dummy cycle → the corresponding data out on SO
- continuous data out (n-byte) →→
- completed by CS=high

\* The data output starts from the falling edge of SCK(39th clock)

The Address is latched on rising edge of SCK. It is necessary to add 1 dummy byte cycle after address is latched, and the corresponding data is shifted out on SO by the falling edge of SCK. The address is automatically incremented to the next higher address after each byte data is shifted out. If the SCK input is continued after the internal address arrives at the highest address (0FFFFFFh), the internal address returns to the lowest address (000000h). By setting CS to high, the device is deselected, and the read cycle is completed. While the device is deselected, the output pin SO is in a high-impedance state.

Figure 7. High-Speed Read (RDHS)



• Address A23 to A20 are "Don't care".

**10-6. Dual read**

There are two Dual read commands, the Dual Output Read (RDDO) and the Dual I/O Read (RDIO). They achieve the twice speed-up from "High-Speed Read (RDHS: 0Bh)". The command list is shown in "Table.1-2. Command Settings (Dual SPI)"

Pin Configurations at Dual SPI Mode

| Standard SPI |   | Dual SPI |
|--------------|---|----------|
| SI           | → | SIO0     |
| SO           | → | SIO1     |

**10-6-1. Dual Output Read command (RDDO)\_\_\_\_\_ Maximum Clock frequency: 66MHz**

The SI and SO pins change into the input/output pin (SIOx) during this operation. It makes the data output x2 bit and has achieved a high-speed output. bit7, 5, 3 and bit1 are output from SIO0. bit6, 4, 2 and bit0 are output from SIO1.

"Figure 8. Dual Output Read (RDDO)" shows the timing waveforms.

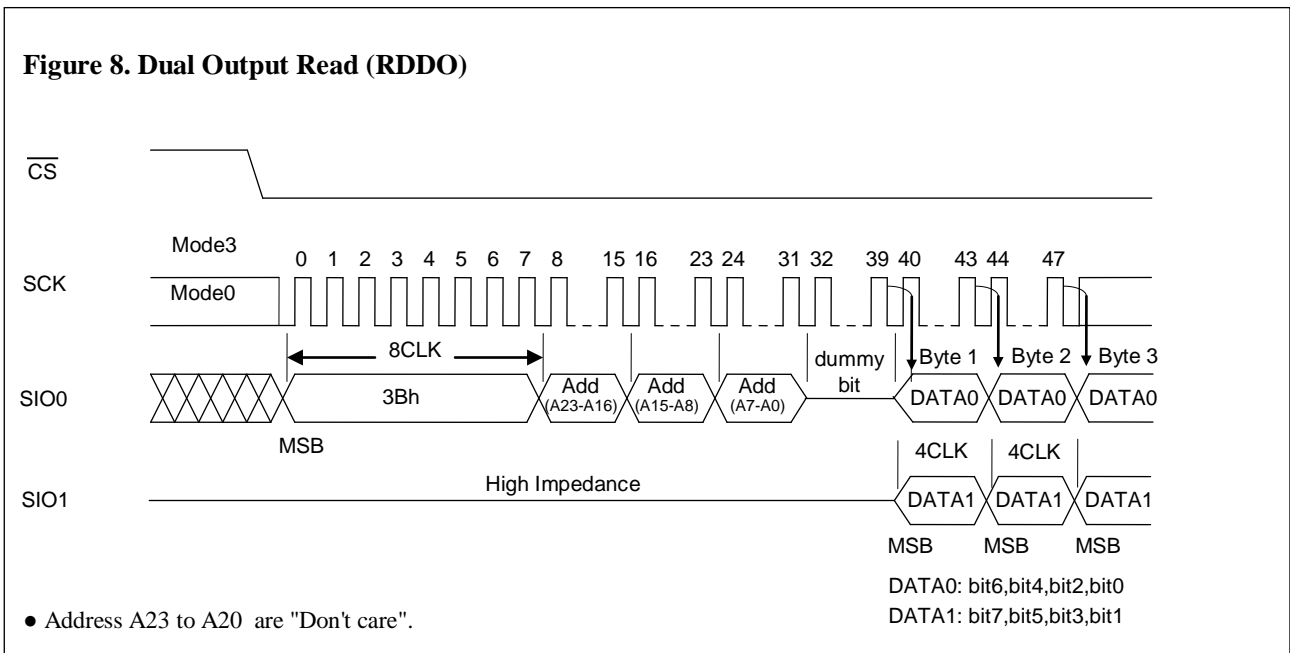
The sequence of RDDO operation :

- CS goes to low → input RDDO command (3Bh) → 3 Byte address (A23-A0) input on SI
- 1 byte dummy cycle → the corresponding data out on SI/SIO0 and SO/SIO1
- continuous data out (n-byte) per 4clock →→
- completed by CS=high

\* The data output starts from the falling edge of SCK(39th clock)

|         |             |
|---------|-------------|
|         | Output Data |
| SI/SIO0 | bit6,4,2,0  |
| SO/SIO1 | bit7,5,3,1  |

The Address is latched on rising edge of SCK. It is necessary to add 1 dummy byte cycle after address is latched, and the corresponding data is shifted out on SI/SIO0 and SO/SIO1 by the falling edge of SCK. The address is automatically incremented to the next higher address after each byte data (4 clock cycles) is shifted out. If the SCK input is continued after the internal address arrives at the highest address (0FFFFFFh), the internal address returns to the lowest address (000000h). By setting CS to high, the device is deselected, and the read cycle is completed. While the device is deselected, the output pin SO is in a high-impedance state.



**10-6-2. Dual I/O Read command (RDIO)\_\_\_\_\_ Maximum Clock frequency: 66MHz**

The SI and SO pins change into the input/output pin (SIOx) during this operation. It makes the address input and data output x2 bit and has achieved a high-speed output. Add1 (A23, A21, -, A3 and A1) is input from SIO1 and Add0 (A22, A20, -, A2 and A0) is input from SIO0. bit7, 5, 3 and bit1 are output from SIO0. bit6, 4, 2 and bit0 are output from SIO1.

"Figure 9. Dual I/O Read (RDIO)" shows the timing waveforms.

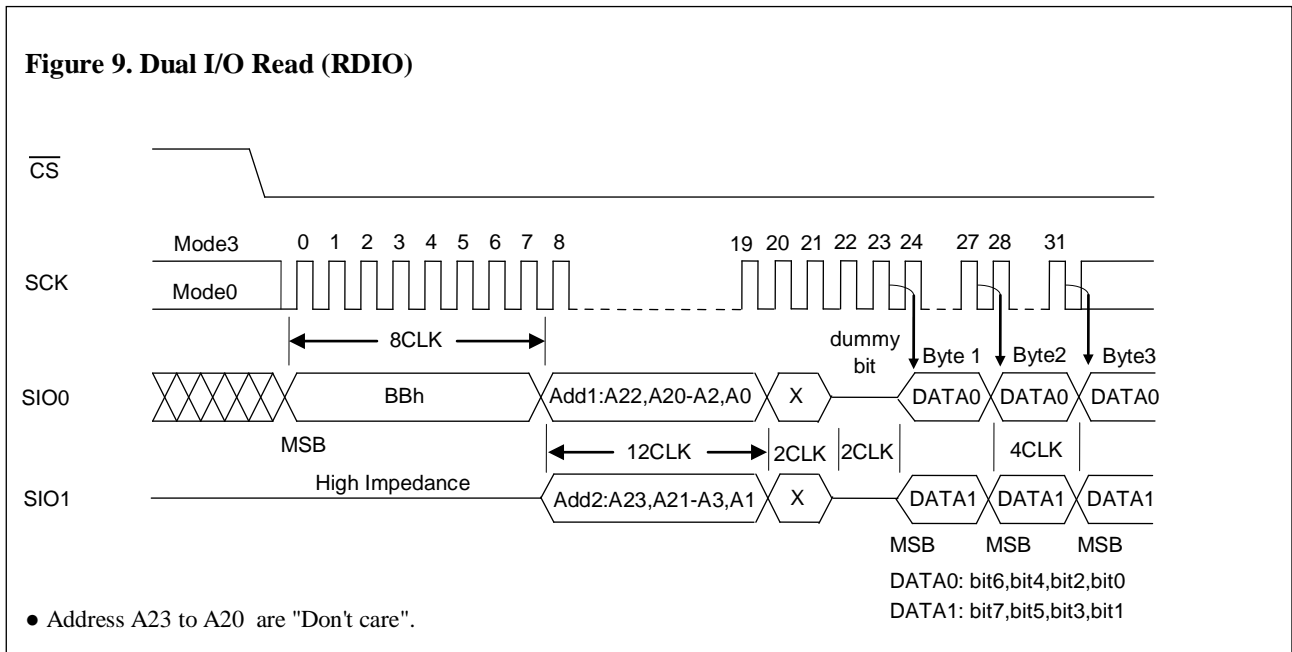
The sequence of RDIO operation :

- CS goes to low → input RDIO command (BBh)
- 3 Byte address (A23-A0) input on SI/SIO0 and SO/SIO1 by 12 clock cycle
- 2 dummy clock (SI/SIO0 and SO/SIO1 are don't care)
- + 2 dummy clock (must set SI/SIO0 and SO/SIO1 high impedance)
- the corresponding data out on SI/SIO0 and SO/SIO
- continuous data out (n-byte) per 4clock →→
- completed by CS=high

\* The data output starts from the falling edge of SCK(23th clock)

|         | Input Address      | Output Data |
|---------|--------------------|-------------|
| SI/SIO0 | A22,20,18 --,A2,A0 | bit6,4,2,0  |
| SO/SIO1 | A23,21,19 --,A3,A1 | bit7,5,3,1  |

The Address is latched on rising edge of SCK. It is necessary to add 4 dummy clocks after address is latched, 2CLK of the latter half of the dummy clock is in the state of high impedance, the controller can switch I/O for this period. The corresponding data is shifted out on SI/SIO0 and SO/SIO1 by the falling edge of SCK. The address is automatically incremented to the next higher address after each byte data (4 clock cycles) is shifted out. If the SCK input is continued after the internal address arrives at the highest address (0FFFFFFh), the internal address returns to the lowest address (000000h). By setting CS to high, the device is deselected, and the read cycle is completed. While the device is deselected, the output pin SO is in a high-impedance state.



**10-7. Small Sector Erase (SSE)**

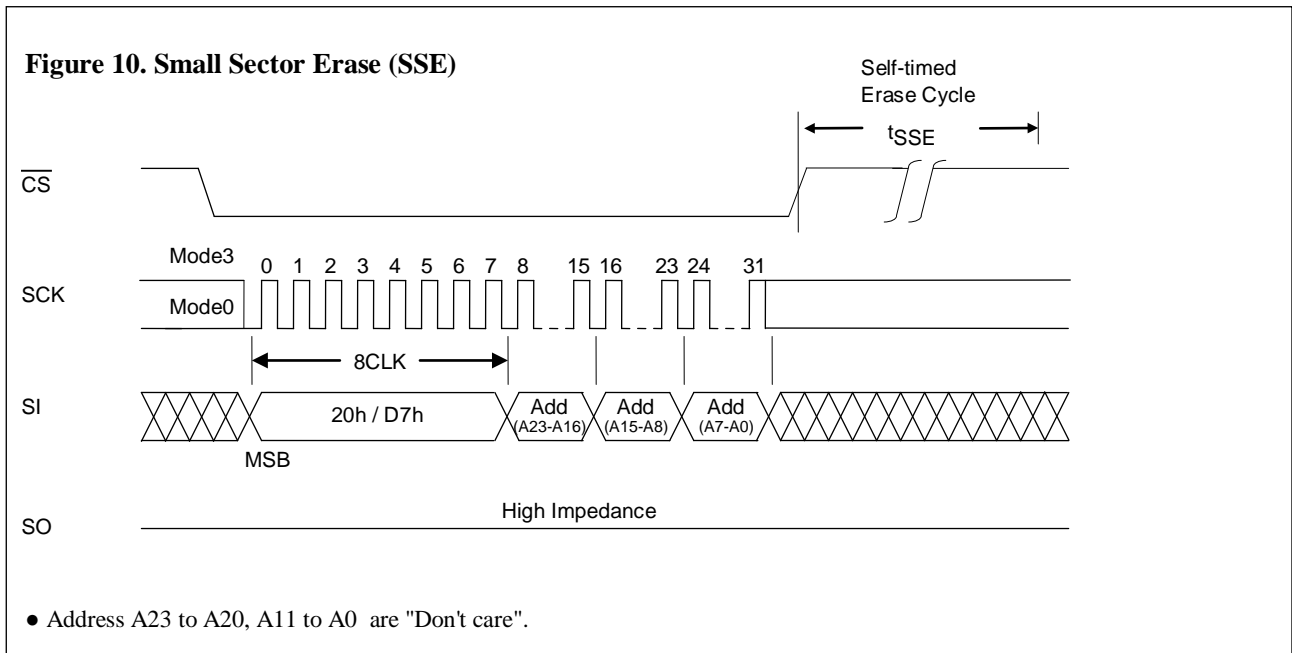
Small Sector Erase is an operation that sets the memory cell data in any small sector to "1". A small sector consists of 4Kbytes.

"Figure 10. Small Sector Erase (SSE)" shows the timing waveforms.

"Figure 32. Small Sector Erase Flowcharts" shows the flowcharts.

The sequence of SSE operation :  
 CS goes to low → input SSE command (20h or D7h) → 3 Byte address (A23-A0) input on SI  
 → CS goes to high (be executed by the rising CS edge)  
 \* A19 to A12 are valid address

After the correct input sequence the internal erase operation is executed by the rising  $\overline{CS}$  edge, and it is completed automatically by the control exercised by the internal timer ( $t_{SSE}$ ). The end of erase operation can also be detected by status register (RDY).



**10-8. Sector Erase (SE)**

Sector Erase is an operation that sets the memory cell data in any sector to "1". A sector consists of 64Kbytes.

"Figure 11. Sector Erase (SE)" shows the timing waveforms.

"Figure 33. Sector Erase Flowcharts" shows the flowcharts.

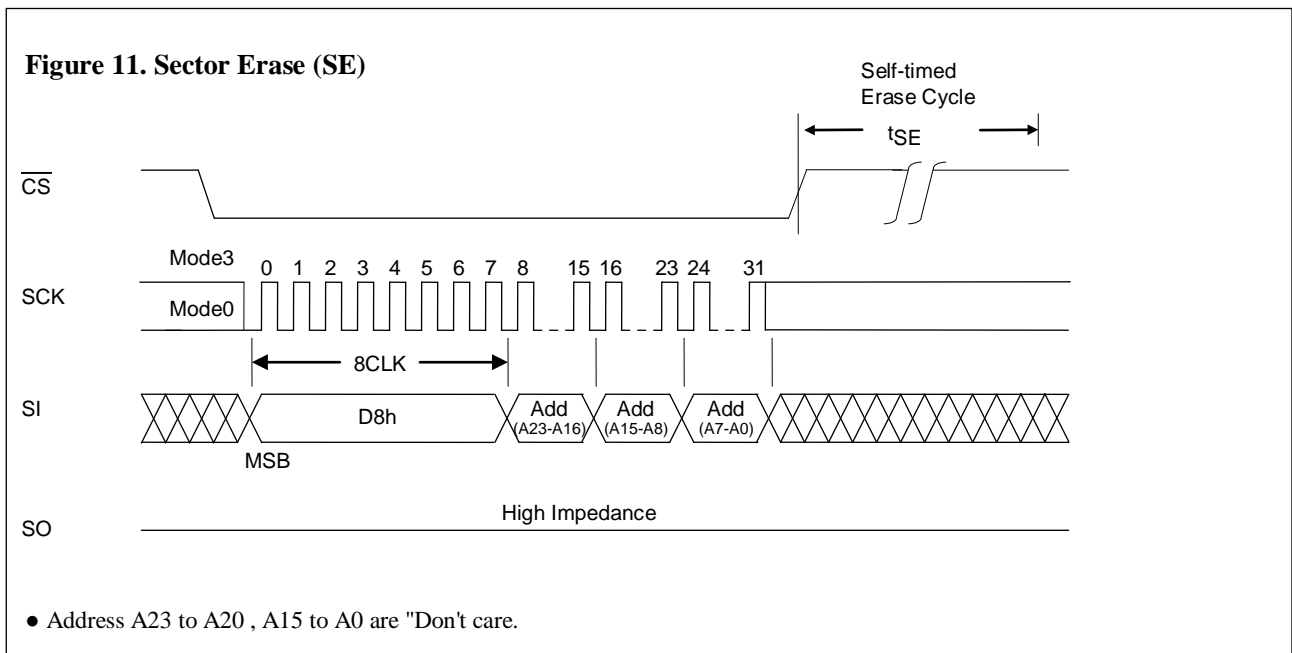
The sequence of SE operation :

CS goes to low → input SE command (D8h) → 3 Byte address (A23-A0) input on SI

→ CS goes to high (be executed by the rising CS edge)

\* A19 to A16 are valid address

After the correct input sequence the internal erase operation is executed by the rising  $\overline{CS}$  edge, and it is completed automatically by the control exercised by the internal timer ( $t_{SE}$ ). The end of erase operation can also be detected by status register (RDY).



**10-9. Chip Erase (CHE)**

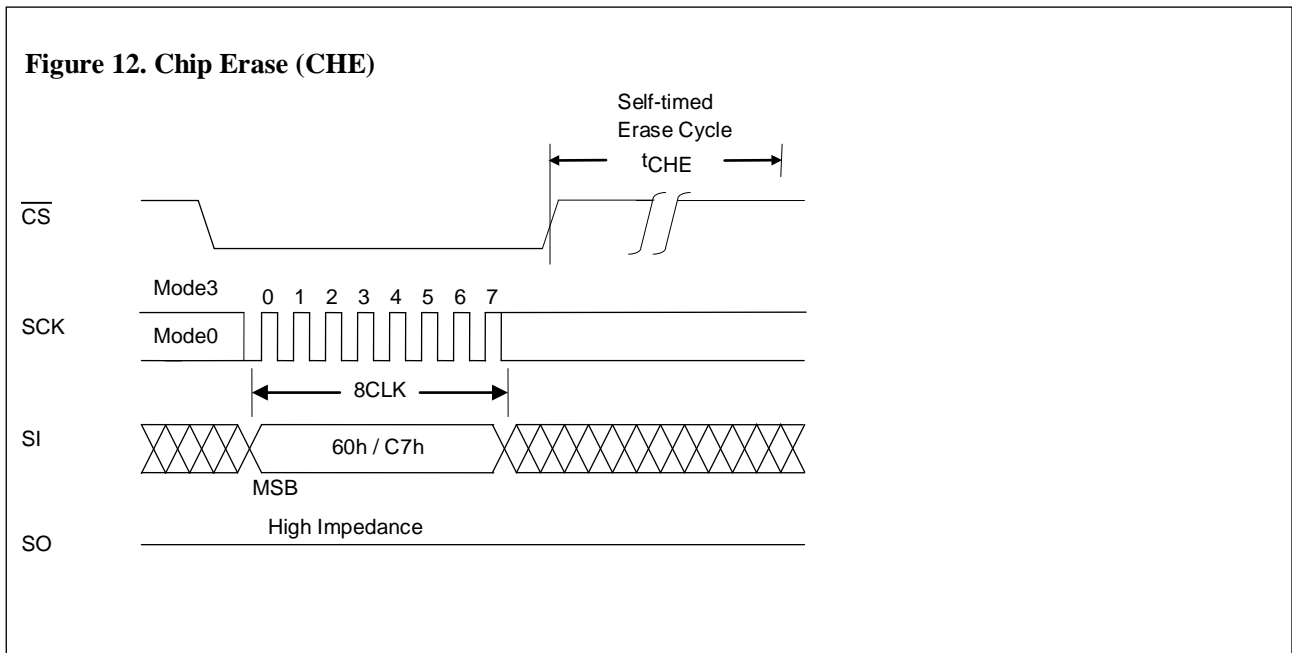
Chip Erase is an operation that sets the memory cell data in all sectors to "1".

"Figure 12. Chip Erase (CHE)" shows the timing waveforms.

"Figure 34. Chip Erase Flowcharts" shows the flowcharts.

The sequence of CHE operation :  
 CS goes to low → input CHE command (60h or C7h)  
 → CS goes to high (be executed by the rising CS edge)

After the correct input sequence the internal erase operation is executed by the rising  $\overline{CS}$  edge, and it is completed automatically by the control exercised by the internal timer (tSE). The end of erase operation can also be detected by status register (RDY).





**10-10. Page Program**

**10-10-1. Normal Page Program (PP)**

**10-10-2. Low-Power Page Program (PPL)**

There are two Page Program commands, Normal program (PP: 02h ) and Low-Power program (PPL: 0Ah) These two commands are completely functionally the same. By selecting the Low-Power program (PPL), the operating current is reduced, but the program cycle time is extended. ( $I_{ccpp} > I_{ccppl}$  ,  $t_{PPL} > t_{PP}$ )

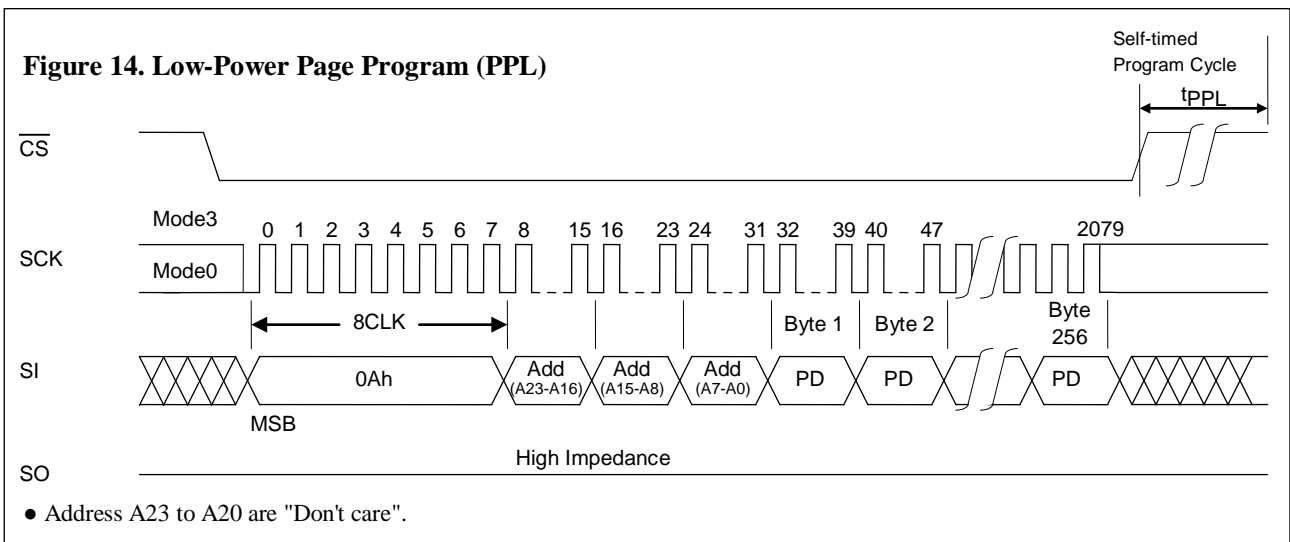
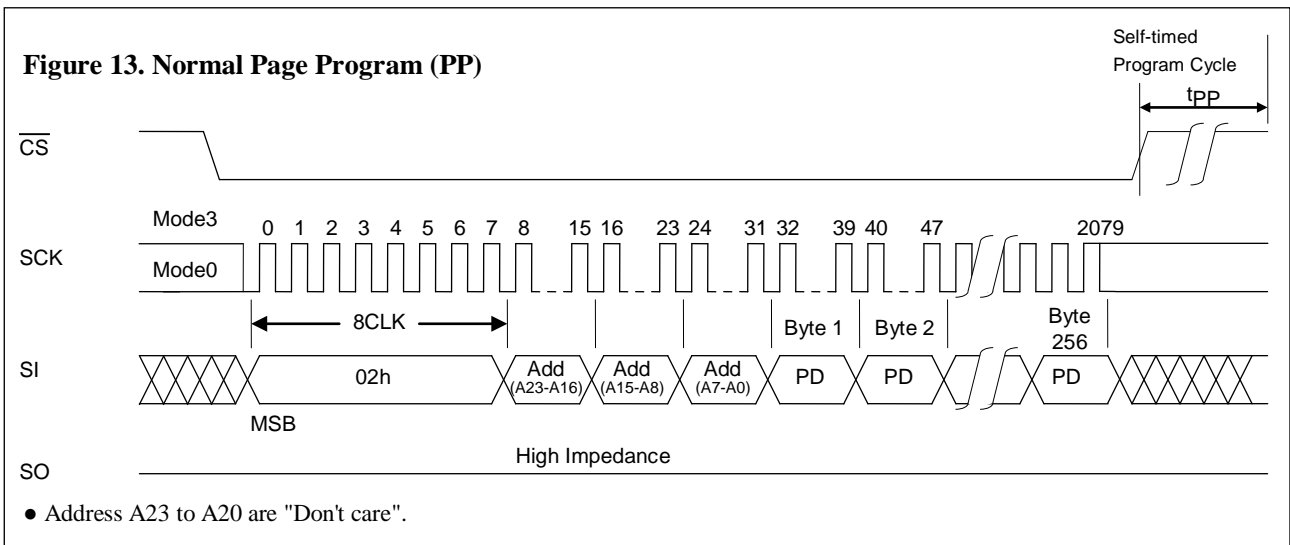
Page Program is an operation that programs any number of bytes from 1 to 256 bytes within the same sector page (page addresses: A19 to A8). Before initiating Page Program, the data on the page concerned must be erased using Small Sector Erase, Sector Erase, or Chip Erase. Page Program (PP, PPL) allows only previous erased data (FFh).

"Figure 13. Normal Page Program (PP)". "Figure 14. Low-power Page Program (PPL)" shows the timing waveforms. "Figure 35. Page Program Flowcharts" shows the flowcharts.

The sequence of PP or PPL operation :

- CS goes to low → input PP command (02h) or PPL command (0Ah)
- 3 Byte address (A23-A0) input on SI
- n-Byte data input on SI →→
- CS goes to high (be executed by the rising CS edge)

The program data must be loaded in 1-byte increments. If the data loaded has exceeded 256 bytes, the 256 bytes loaded last are programmed. After the correct input sequence the internal program operation is executed by the rising CS edge, and it is completed automatically by the control exercised by the internal timer ( $t_{PP}$  or  $t_{PPL}$ ). The end of program operation can also be detected by status register (RDY).



**10-11. Write Suspend (WSUS)**

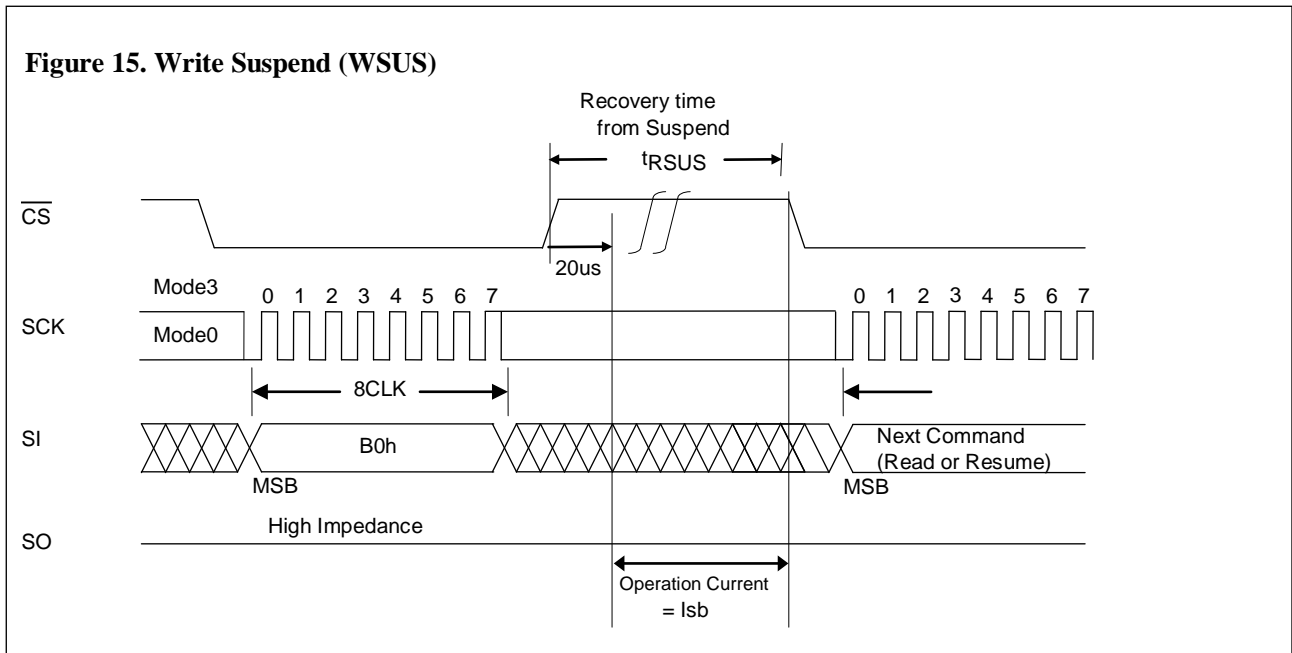
The Write Suspend (WSUS) allow the system to interrupt Small Sector Erase (SSE), Sector Erase (SE), Chip Erase (CHE) or Page Program (PP, PPL).

"Figure 15. Write Suspend (WSUS)" shows the timing waveforms.

The sequence of WSUS operation :  
 CS goes to low → input WSUS command (B0h)  
 → CS goes to high (be executed by the rising CS edge)

After the command has been input, the device becomes consumption current equivalent to standby within 20 us. The recovery time ( $t_{RSUS}$ ) is needed before next command from suspend. The internal operation status could be checked by using status register RDY bit or SUS bit, but the device will not accept another command until it is ready.

- The Write Suspend is valid Erase cycle (SSE, SE and CHE) or Program cycle (PP, PPL).
- If the Erase (SSE, SE, CHE) or Program (PP, PPL) entry during the suspension, the suspension will be canceled automatically. And a new Erase (SSE, SE, CHE), Program (PP, PPL) will be executed. In this case, it is necessary to erase/program the suspended area again.
- During Write Suspend, Read (RDSR, RDLP, RDHS, RDDO, RDIO) and Resume (RESM) can be accepted.
- If the Software Reset is executed during the suspension, the suspension will be canceled automatically.



**10-12. Resume (RESM)**

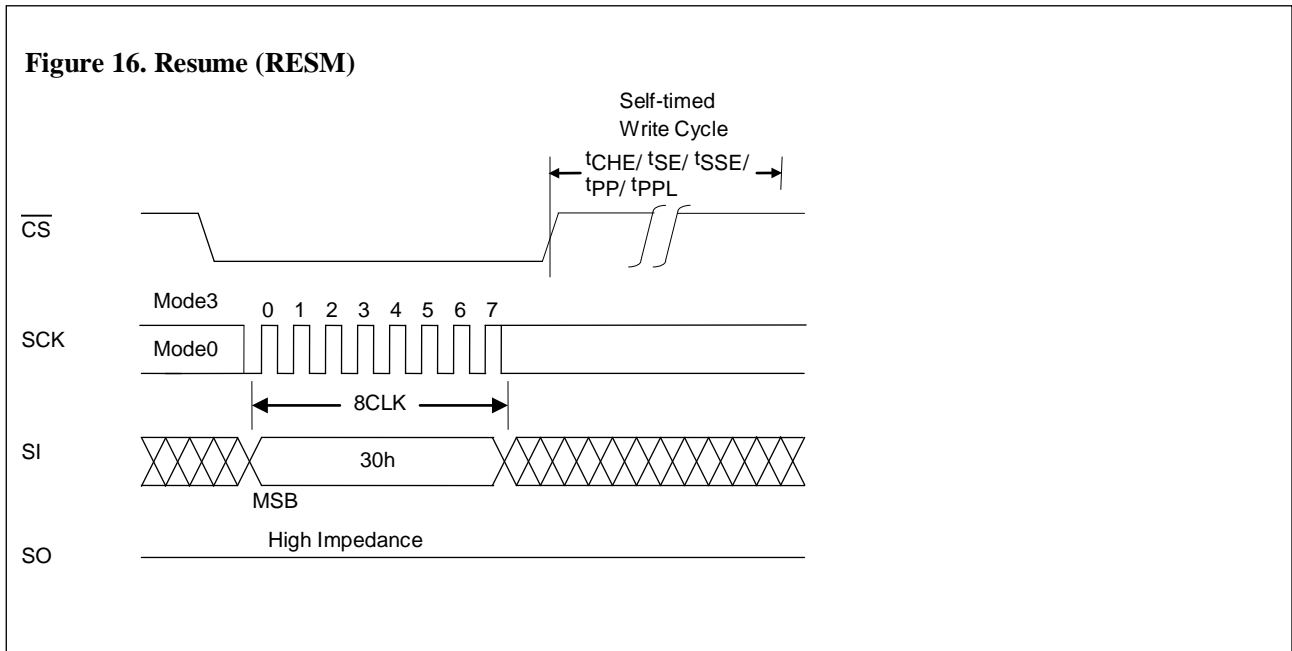
This command (RESM) restarts erase cycle (SSE, SE, CHE) or program cycle (PP, PPL) that was suspended.

"Figure 16. Resume (RESM)" shows the timing waveforms.

The sequence of RESM operation :  
 CS goes to low → input RESM command (30h)  
 → CS goes to high (be executed by the rising CS edge)

The internal operation status could be checked by using status register RDY bit or SUS bit.

This command will be ignored if the previous Write Suspend operation was interrupted by unexpected power off or re-erase/program (cancel of suspend) or Software Reset(RST). To execute Write Suspend (WSUS) again after Resume, it is necessary to wait for some time (tSUS).



**10-13. Read ID**

Read ID is an operation that reads the manufacturer code (RJID) and device ID information (RID). These Read ID commands are not accepted during writing. There are two methods of reading the silicon ID, each of which is assigned a device ID.

**10-13-1. Read JEDEC ID (RJID)**

This command (RJID) is compatible with the JEDEC standard for SPI compatible serial memories.

"Table 6. JEDEC ID codes" lists the silicon ID codes.

"Figure 17. Read JEDEC ID (RJID)" shows the timing waveforms.

The sequence of RJID operation :

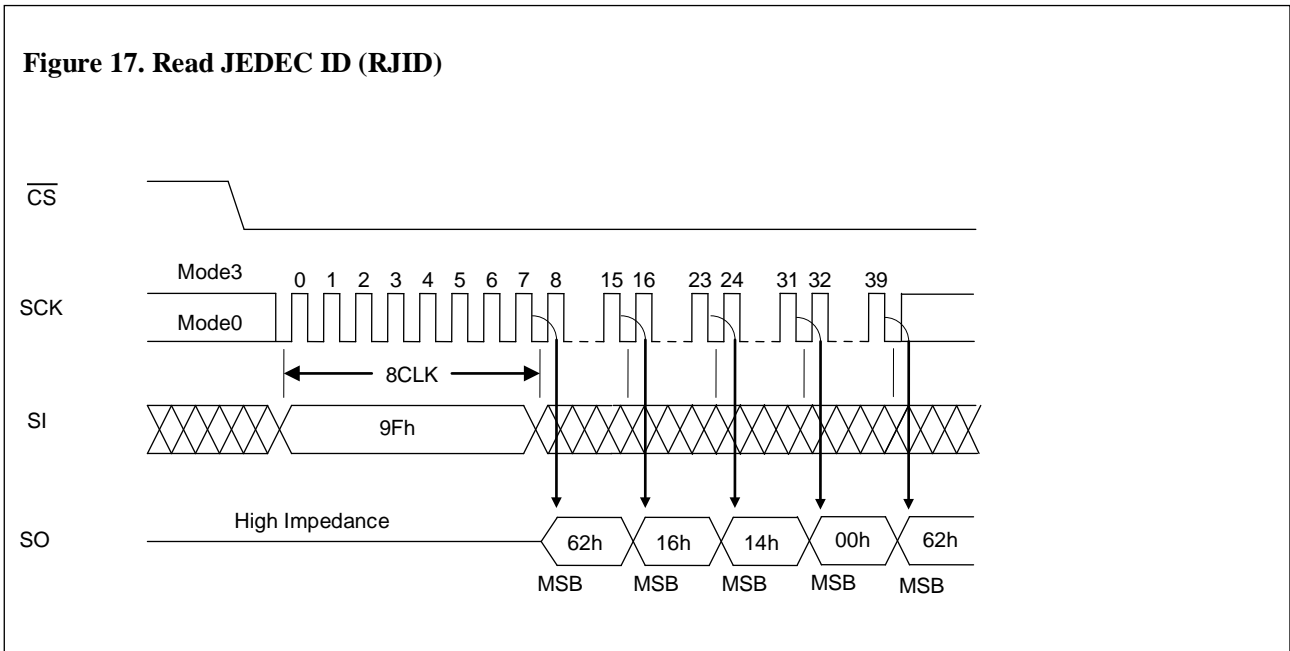
- CS goes to low → input RJID command (9Fh)
- Manufacture code (62h) out on SO → Memory type code (16h) out on SO
- Memory capacity code out on SO (14h) → Reserve code (00h) →→
- completed by CS=high

\* The 4-byte code is output repeatedly as long as clock inputs are present  
 \* The data output starts from the falling edge of SCK(7th clock)

By setting  $\overline{CS}$  to high, the device is deselected, and Read JEDEC ID cycle is completed. While the device is deselected, the output pin SO is in a high-impedance state.

**Table 6. JEDEC ID codes**

|                   |                      |              |
|-------------------|----------------------|--------------|
|                   |                      | Output code  |
| Manufacturer code |                      | 62h          |
| 2 byte device ID  | Memory type          | 16h          |
|                   | Memory capacity code | 14h (8M Bit) |
| Reserve code      |                      | 00h          |



**10-13-2. Read Device ID (RID)**

This command (RID) is an operation that reads the Device ID.

"Table 7. Device ID code" lists the device ID codes.

"Figure 18. Read Device ID (RID)" shows the timing waveforms.

The sequence of RID operation :

- CS goes to low → input RID command (ABh) → 3 byte dummy cycle
- Device ID (87h) out on SO →→
- completed by CS=high

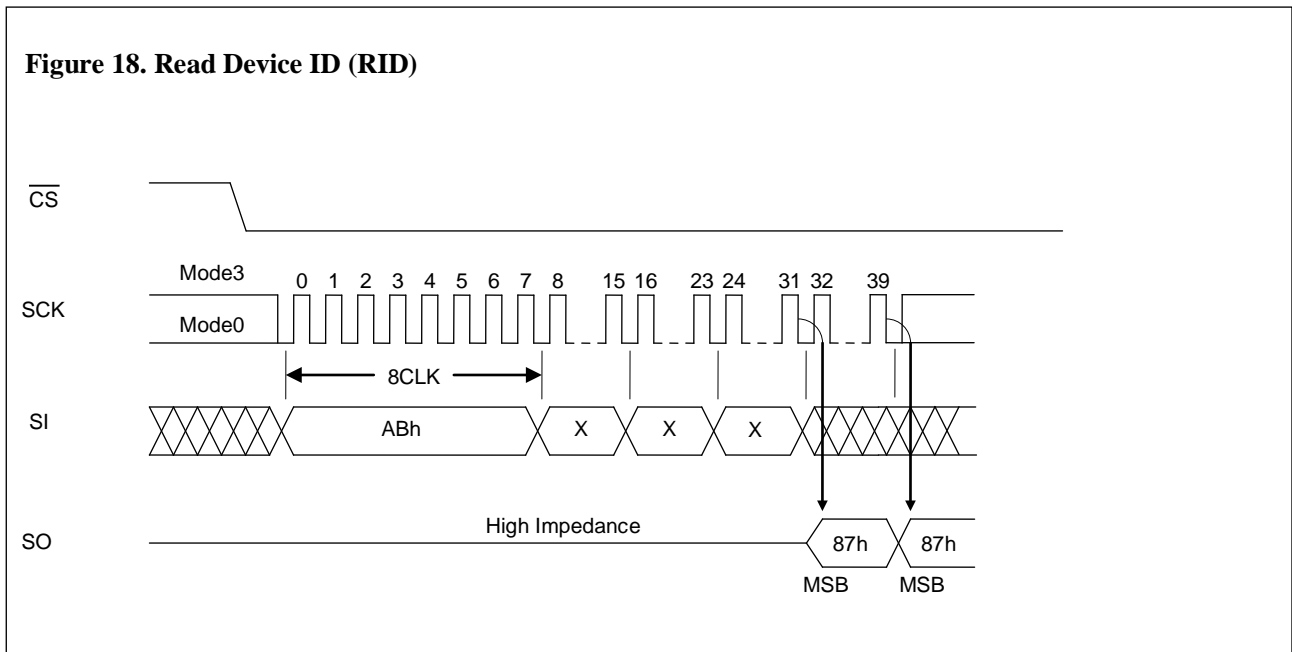
\* The Device ID (87h) is output repeatedly as long as clock inputs are present

\* The data output starts from the falling edge of SCK(31th)

By setting  $\overline{\text{CS}}$  to high, the device is deselected, and Read ID cycle is completed. While the device is deselected, the output pin SO is in a high-impedance state.

**Table 7. Device ID code**

|                  | Output Code       |
|------------------|-------------------|
| 1 byte device ID | 87h<br>(LE25S81A) |



**10-14. Deep Power-down (DP)**

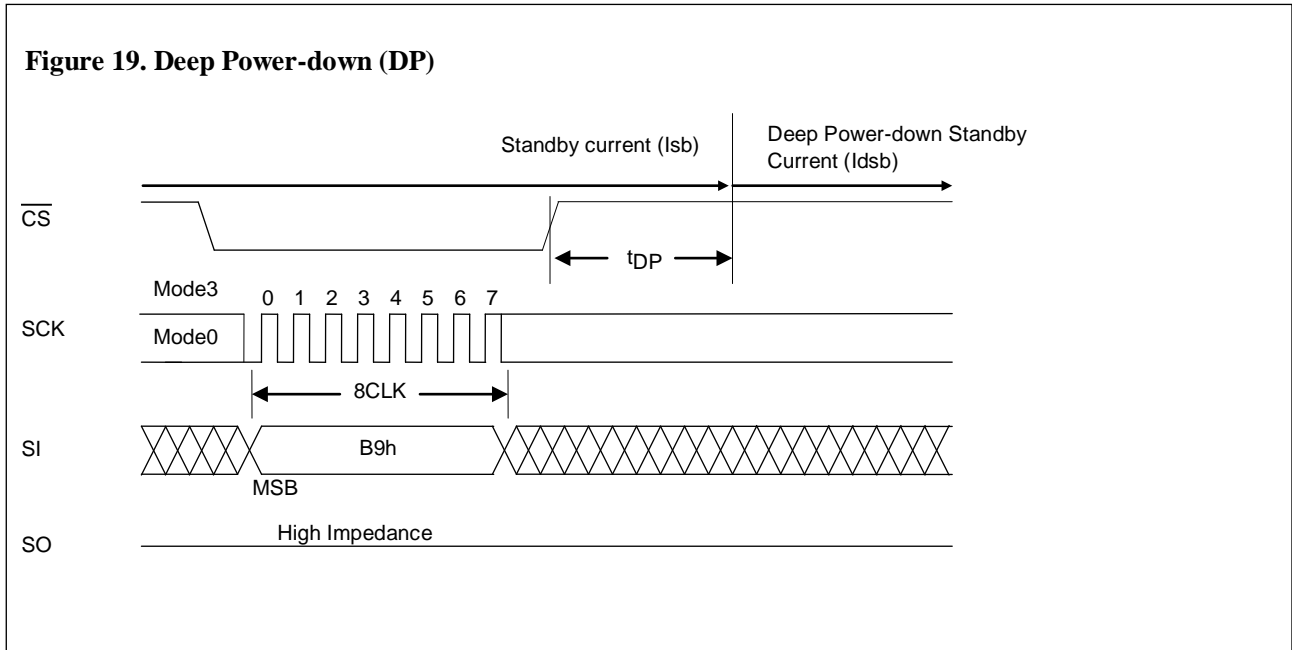
The standby current can be further reduced with this command (DP).

"Figure 19. Deep Power-down (DP)" shows the timing waveforms.

The sequence of DP operation :  
 CS goes to low → input DP command (B9h) \_\_\_\_\_  
 → CS goes to high (be executed by the rising CS edge)

The deep power-down command issued during an internal write operation will be ignored.

The deep power-down state is exited using the deep power-down exit (EDP). All other commands are ignored.



**10-15. Exit Deep Power-down (EDP) / Read Device ID (RDDI)**

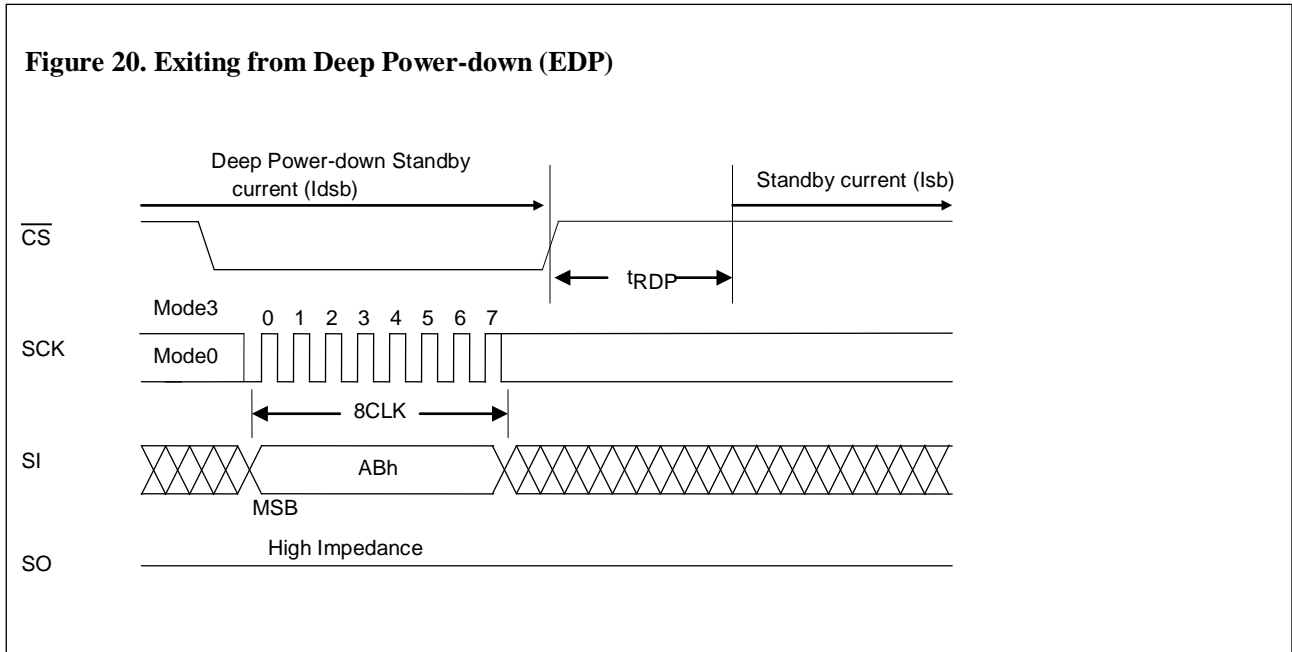
The Exit Deep Power-down (EDP) / Read Device ID (RID) command is a multi-purpose command. It can be used to exit the device from the deep power-down state, or read the device ID information.

**Exit Deep Power-down (EDP)**

The exit deep power-down command consists only of the first byte cycle, and it is initiated by inputting (ABh).

"Figure 20. Exiting from Deep Power-down" shows the timing waveforms.

The sequence of EDP operation :  
 CS goes to low → input EDP command (ABh)  
 → CS goes to high (be executed by the rising CS edge)



**Read Device ID (RDDI)**

Also the exit from deep power-down is completed by one byte cycle or more of the Read Device ID (RID: ABh). "Table 7. Device ID code" lists the device ID codes.

"Figure 21. Read Device ID " shows the timing waveforms.

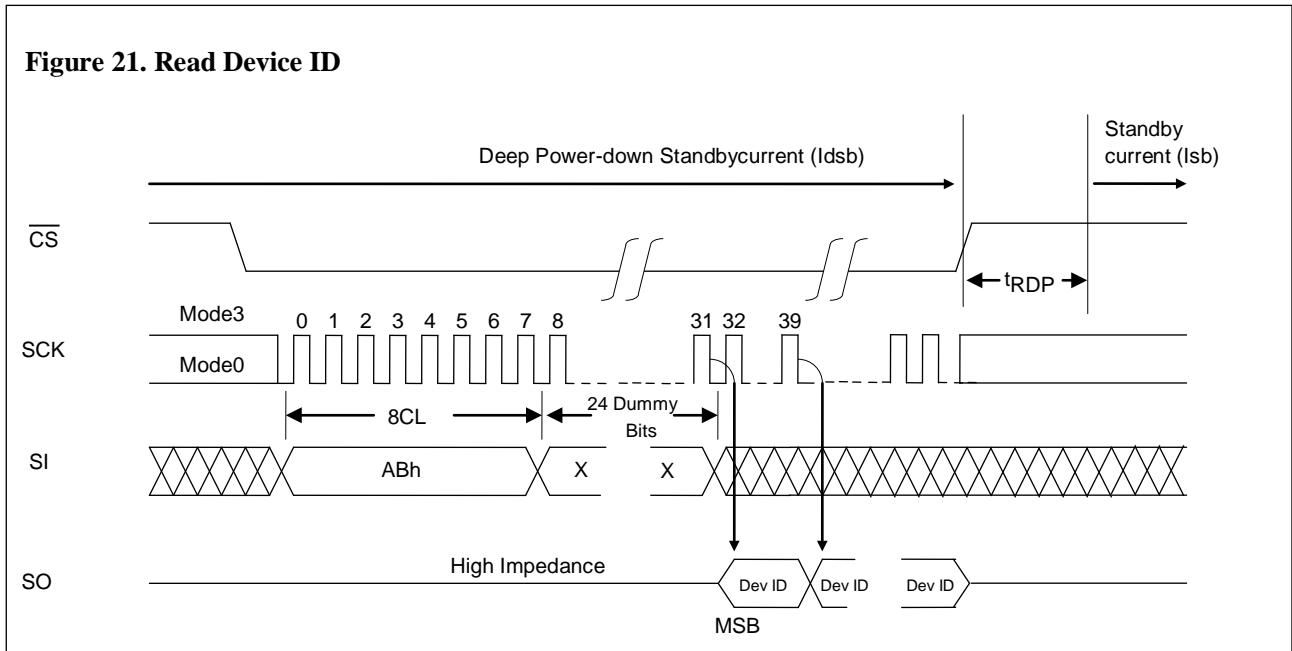
The sequence of EDP & RID operation :

- CS goes to low → input RID command (ABh) → 3 byte dummy cycle
- Device ID out on SO →→
- completed by CS=high

\* The Device ID is output repeatedly as long as clock inputs are present

\* The data output starts from the falling edge of SCK(31th clock)

By setting  $\overline{\text{CS}}$  to high, the device is deselected, and Read ID cycle is completed. While the device is deselected, the output pin SO is in a high-impedance state.





**10-16. Software Reset**

The Software Reset reset the device to the state just after power-on. This operation consists of two commands: the Reset Enable (RSTEN) and the Reset command (RST).

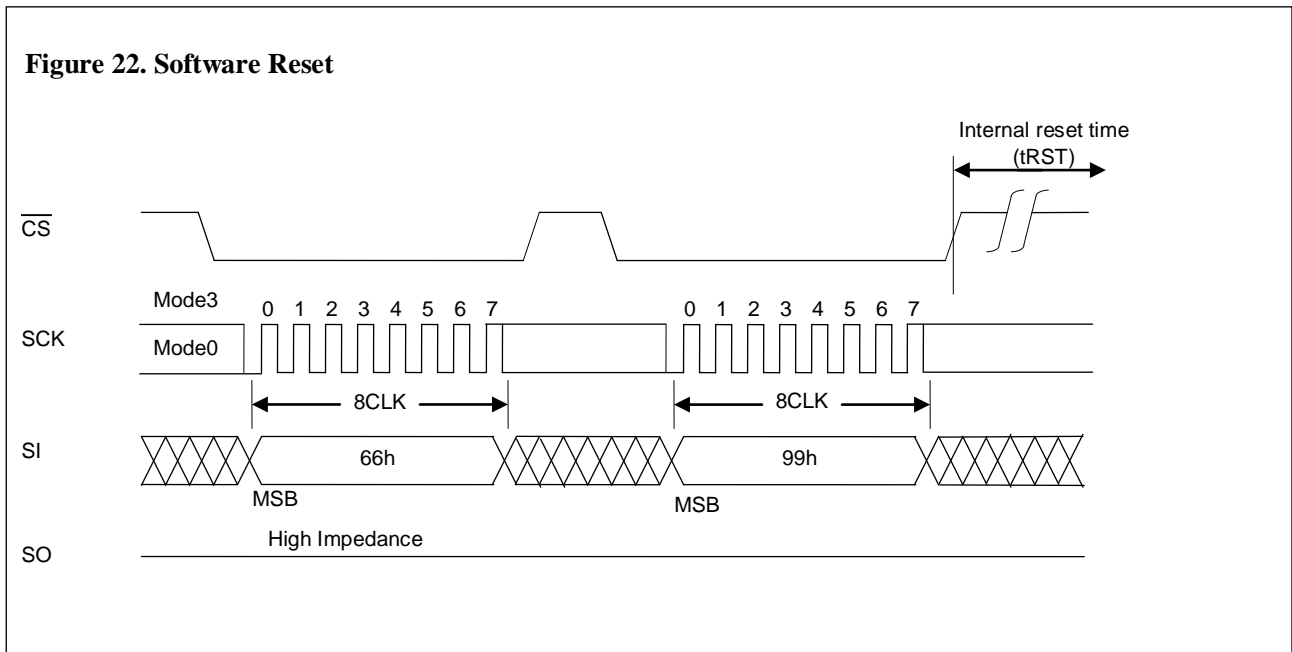
"Figure 22. Software Reset" shows the timing waveforms.

The sequence of Software Reset operation :

- CS goes to low → input RSTEN command (66h)
- CS goes to high
- CS goes to low → input RST command (99h)
- CS goes to high (be executed by the rising CS edge)

When the Software Reset is executed, an internal write (erase/program) operation is cancel, a suspended status is reset, and all volatility status register bits (WEN/ RDY/SUS) are reset. After the internal reset time (tRST), the device will become stand-by state. If the Software Reset is executed during a write (erase/program) operation, any dates on the write operation will be broken.

The Reset command must input just after input the Reset Enable command. If another command input after the Reset Enable command, the Reset-Enable state will be invalid.



**10-17. Read SFDP (RSFDP)**

The Read SFDP (Serial Flash Discoverable Parameter) is an operation that reads the parameter about device configurations, available commands and other features. The SFDP parameters are stored in internal parameter tables. These parameter tables can be interrogated by host system software to enable adjustments needed to accommodate divergent features from multiple vendors. SFDP is a standard of JEDEC. JESD216. Rev 1.0.

"Table 8. SFDP Header" shows SFDP Header.

"Table 9. SFDP Parameter Table" shows SFDP Parameter Table.

"Figure 23. Read SFDP (RSFDP)" shows the timing waveforms.

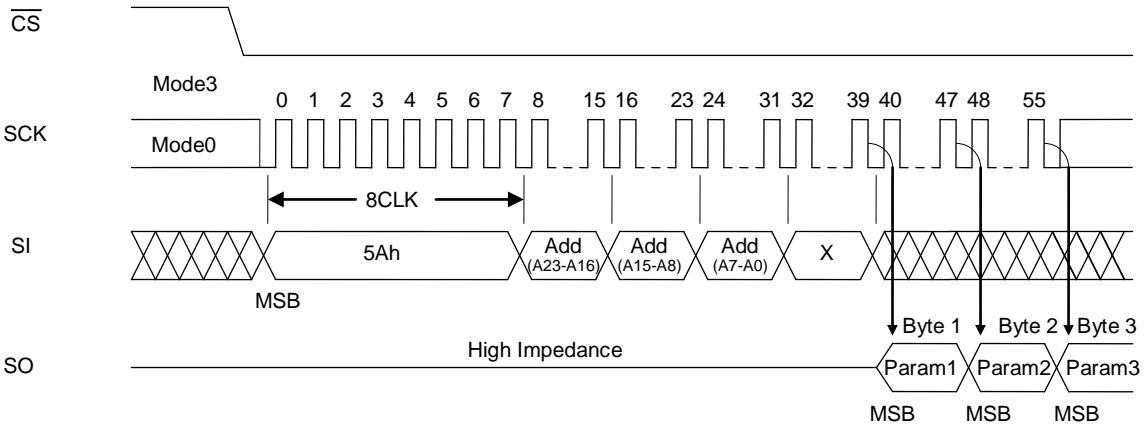
The sequence of RSFDP operation :

- CS goes to low → input RSFDP command (5Ah) → 3 Byte address (A23-A0) input on SI
- 1 byte dummy cycle → the corresponding parameter out on SO
- continuous parameter out (n-byte) →→
- completed by CS=high

\* A10 to A0 are valid address  
 \* The parameter output starts from the falling edge of SCK(39th clock)

The Address is latched on rising edge of SCK. It is necessary to add 1 dummy byte cycle after address is latched, and the corresponding parameter is shifted out on SO by the falling edge of SCK. The address is automatically incremented to the next higher address after each byte parameter is shifted out. By setting CS to high, the device is deselected, and Read SFDP cycle is completed. While the device is deselected, the output pin SO is in a high-impedance state.

**Figure 23. Read SFDP (RSFDP)**



# LE25S81A

**Table 8. SFDP Header**

SFDP Header 1<sup>st</sup> and 2<sup>nd</sup> DWORD

| Description                 | Comment                    | Byte Address (Hex) | Bits  | Data (Hex) |
|-----------------------------|----------------------------|--------------------|-------|------------|
| SFDP Signature              | 50444653h (SFDP)           | 00h                | 7:0   | 53h        |
|                             |                            | 01h                | 15:8  | 46h        |
|                             |                            | 02h                | 23:16 | 44h        |
|                             |                            | 03h                | 31:24 | 50h        |
| SFDP Minor Revision Number  | Start from 00h             | 04h                | 7:0   | 05h        |
| SFDP Major Revision Number  | Start from 01h             | 05h                | 15:8  | 01h        |
| Number of Parameter Headers | 02h indicates 3 parameters | 06h                | 23:16 | 02h        |
| Unused                      |                            | 07h                | 31:24 | FFh        |

1<sup>st</sup> Parameter Header (JEDEC Basic Flash parameters)

| Description                             | Comment   | Byte Address (Hex) | Bits  | Data (Hex) |
|---|---|--------------------|-------|------------|
| ID number (JEDEC ID)                    | 00h(JEDEC specified header)                                       | 08h                | 7:0   | 00h        |
| Parameter Table Minor Revision Number   | Start from 00h  | 09h                | 15:8  | 00h        |
| Parameter Table Major Revision Number   | Start from 01h  | 0Ah                | 23:16 | 01h        |
| Parameter Table Length (in double word) | How many DWORDs in the Parameter table<br>10h indicates 16 DWORDs | 0Bh                | 31:24 | 10h        |
| Parameter Table Pointer (PTP)           | First address of JEDEC Flash Parameter table                      | 0Ch                | 7:0   | 40h        |
|   |   | 0Dh                | 15:8  | 00h        |
|   |   | 0Eh                | 23:16 | 00h        |
| Unused                                  |   | 0Fh                | 31:24 | FFh        |

2<sup>nd</sup> Parameter Header (Vender parameters 1)

| Description                                  | Comment  | Byte Address (Hex) | Bits  | Data (Hex) |
|--|--|--------------------|-------|------------|
| ID number (ON Semiconductor manufacturer ID) | 62h(ON Semiconductor manufacturer ID)                            | 10h                | 7:0   | 62h        |
| Parameter Table Minor Revision Number        | Start from 00h   | 11h                | 15:8  | 00h        |
| Parameter Table Major Revision Number        | Start from 01h   | 12h                | 23:16 | 01h        |
| Parameter Table Length (in double word)      | How many DWORDs in the Parameter table<br>04h indicates 4 DWORDs | 13h                | 31:24 | 04h        |
| Parameter Table Pointer (PTP)                | First address of On Semiconductor Parameter table                | 14h                | 7:0   | C0h        |
|  |  | 15h                | 15:8  | 00h        |
|  |  | 16h                | 23:16 | 00h        |
| Unused                                       |  | 17h                | 31:24 | FFh        |

# LE25S81A

**Table 9. SFDP Parameter Tables**

Parameter Table : JDEC Basic Flash Parameter Tables (from 1th DWORD to 4<sup>th</sup> DWORD)

| Description   | Comment   | Byte Address (Hex)       | Bits  | Data (Binary) | Data (Hex) |
|---|---|--------------------------|-------|---------------|------------|
| Block/Sector Erase Sizes  | 00b: Reserved<br>01b: support 4 KB Erase<br>10b: Reserved<br>11b: not support 4KB Erase   | 40h                      | 1:0   | 01b           | E5h        |
| Write Granularity   | 0: 1Byte, 1:64 Byte or larger   |                          | 2     | 1b            |            |
| Volatile Status Register Block Protect bits                             | 0: Non-volatile<br>1: Volatile  |                          | 3     | 0b            |            |
| Write Enable Instruction Select for Writing to Volatile Status Register | 0: use 50h opcode, 1: use 06h opcode<br>Note: If target flash status register is nonvolatile, then bits 3 and 4 must be set to 00b. |                          | 4     | 0b            |            |
| Unused  | Contains 111b and can never be changed  |                          | 7:5   | 111b          |            |
| 4KB Erase Instruction   | 20h   | 41h                      | 15:8  | 0010_0000b    | 20h        |
| (1-1-2) Fast Read   | 0=not support 1=support   | 42h                      | 16    | 1b            | 91h        |
| Address Bytes   | 00: 3Byte only, 01: 3 or 4Byte,<br>10: 4Byte only, 11: Reserved   |                          | 18:17 | 00b           |            |
| Double Transfer Rate (DTR) Clcking                                      | 0=not support 1=support   |                          | 19    | 0b            |            |
| (1-2-2) Fast Read   | 0=not support 1=support   |                          | 20    | 1b            |            |
| (1-4-4) Fast Read   | 0=not support 1=support   |                          | 21    | 0b            |            |
| (1-1-4) Fast Read   | 0=not support 1=support   |                          | 22    | 0b            |            |
| Unused  |   |                          | 23    | 1b            |            |
| Unused  |   |                          | 43h   | 31:24         |            |
| Flash Memory Density  | 8 M bits  | 44h<br>45h<br>46h<br>47h | 31:0  | -             | 007FFFFh   |
| (1-4-4) Fast Read Number of Wait states (dummy clocks)                  | 0 0000b: Wait states (dummy Clocks) not support   | 48h                      | 4:0   | 0_0000b       | 00h        |
| (1-4-4) Fast Read Number of Mode Clocks                                 | 000b: Mode Bits not support   |                          | 7:5   | 000b          |            |
| (1-4-4) Fast Read Instruction   |   | 49h                      | 15:8  | 1111_1111b    | FFh        |
| (1-1-4) Fast Read Number of Wait states (dummy clocks)                  | 0 0000b: Wait states (dummy Clocks) not support   | 4Ah                      | 20:16 | 0_0000b       | 00h        |
| (1-1-4) Fast Read Number of Mode Clocks                                 | 000b: Mode Bits not support   |                          | 23:21 | 000b          |            |
| (1-1-4) Fast Read Instruction   |   | 4Bh                      | 31:24 | 1111_1111b    | FFh        |
| (1-1-2) Fast Read Number of Wait states (dummy clocks)                  | 0 0000b: Wait states (dummy Clocks) not support   | 4Ch                      | 4:0   | 0_1000b       | 08h        |
| (1-1-2) Fast Read Number of Mode Clocks                                 | 000b: Mode Bits not support   |                          | 7:5   | 000b          |            |
| (1-1-2) Fast Read Instruction   |   | 4Dh                      | 15:8  | 0011_1011b    | 3Bh        |
| (1-2-2) Fast Read Number of Wait states (dummy clocks)                  | 0 0000b: Wait states (dummy Clocks) not support   | 4Eh                      | 20:16 | 0_0100b       | 04h        |
| (1-2-2) Fast Read Number of Mode Clocks                                 | 000b: Mode Bits not support   |                          | 23:21 | 000b          |            |
| (1-2-2) Fast Read Instruction   |   | 4Fh                      | 31:24 | 1011_1011b    | BBh        |

# LE25S81A

Parameter Table : JDEC Basic Flash Parameter Tables (from 5th DWORD to 8th DWORD)

| Description  | Comment  | Byte Address (Hex) | Bits  | Data (Binary) | Data (Hex)        |
|--|--|--------------------|-------|---------------|-------------------|
| (2-2-2) Fast Read                                      | 0=not support 1=support  | 50h                | 0     | 0b            | EEh               |
| Reserved   | Default all 1's  |                    | 3:1   | 111b          |                   |
| (4-4-4) Fast Read                                      | 0=not support 1=support  |                    | 4     | 0b            |                   |
| Reserved   | Default all 1's  |                    | 7:5   | 111b          |                   |
| Reserved   | Default all 1's  | 51h<br>52h<br>53h  | 31:8  | -             | FFh<br>FFh<br>FFh |
| Reserved   | Default all 1's  | 54h<br>55h         | 15:0  | -             | FFh<br>FFh        |
| (2-2-2) Fast Read Number of Wait states (dummy clocks) | 0 0000b: Wait states (dummy Clocks) not support                    | 56h                | 20:16 | 0_0000b       | 00h               |
| (2-2-2) Fast Read Number of Mode Clocks                | 000b: Mode Bits not support  |                    | 23:21 | 000b          |                   |
| (2-2-2) Fast Read Instruction                          |  | 57h                | 31:24 | 1111_1111b    | FFh               |
| Reserved   | Default all 1's  | 58h<br>59h         | 15:0  | -             | FFh<br>FFh        |
| (4-4-4) Fast Read Number of Wait states (dummy clocks) | 0 0000b: Wait states (dummy Clocks) not support                    | 5Ah                | 20:16 | 0_0000b       | 00h               |
| (4-4-4) Fast Read Number of Mode Clocks                | 000b: Mode Bits not support  |                    | 23:21 | 000b          |                   |
| (4-4-4) Fast Read Instruction                          |  | 5Bh                | 31:24 | 1111_1111b    | FFh               |
| Sector Type 1 Size                                     | Sector/block size = 2 <sup>N</sup> bytes<br>0Ch indicates 4Kbytes  | 5Ch                | 7:0   | 0000_1100b    | 0Ch               |
| Sector Type 1 erase Instruction                        |  | 5Dh                | 15:8  | 0010_0000b    | 20h               |
| Sector Type 2 Size                                     | Sector/block size = 2 <sup>N</sup> bytes<br>10h indicates 64Kbytes | 5Eh                | 23:16 | 0001_0000b    | 10h               |
| Sector Type 2 erase Instruction                        |  | 5Fh                | 31:24 | 1101_1000b    | D8h               |

# LE25S81A

Parameter Table : JDEC Basic Flash Parameter Tables (from 9th DWORD to 12th DWORD)

| Description   | Comment  | Byte Address (Hex) | Bits  | Data (Binary) | Data (Hex) |
|---|--|--------------------|-------|---------------|------------|
| Sector Type 3 Size  | Sector/block size = 2 <sup>N</sup> bytes<br>00h indicates not exist  | 60h                | 7:0   | 0000_0000b    | 00h        |
| Sector Type 3 erase Instruction                                   |  | 61h                | 15:8  | 1111_1111b    | FFh        |
| Sector Type 4 Size  | Sector/block size = 2 <sup>N</sup> bytes<br>00h indicates not exist  | 62h                | 23:16 | 0000_0000b    | 00h        |
| Sector Type 4 erase Instruction                                   |  | 63h                | 31:24 | 1111_1111b    | FFh        |
| Multiplier from typical erase time to maximum erase time          | SE (64K-Byte erase):<br>180ms=2 <sup>n</sup> *(n+1)*15ms<br>n=5  | 64h                | 3:0   | 0101b         | 95h        |
| Sector Type 1 Erase, Typical time                                 | SSE (4K-Byte erase)<br>10ms: ((n+1)*1ms=10ms)<br>n=9   |                    | 10:4  | 00_01001b     | 70h        |
| Sector Type 2 Erase, Typical time                                 | SE (64K-Byte erase)<br>15ms: ((n+1)*1ms=15ms)<br>n=14  |                    | 17:11 | 00_01110b     | 00h        |
| Sector Type 3 Erase, Typical time                                 | -  |                    | 24:18 | 00_00000b     | 00h        |
| Sector Type 4 Erase, Typical time                                 | -  |                    | 31:25 | 00_00000b     | 00h        |
| Multiplier from typical time to max time for Page or byte program | (n+1)*0.3ms<br>=0.6ms: n=1, 0.6ms > 0.5ms(spec)  | 68h                | 3:0   | 0001b         | 81h        |
| Page Size   | 256Bytes=2 <sup>8</sup>  |                    | 7:4   | 1000b         |            |
| Page Program Typical time   | (n+1)*64us<br>=320us: n=4, 320us > 300us(spec)   | 69h                | 13:8  | 1_00100b      | E4h        |
| Byte Program Typical time, first byte                             | (n+1)*8us<br>=128us: n=15,   |                    | 15:14 | 1_1111b       |            |
| Byte Program Typical time, additional byte                        | (count+1)*1us/byte<br>=1us/byte: Count=0   | 6Ah                | 18:16 |               | 07h        |
| Chip Erase, Typical time  | (n+1)*16ms<br>=112ms: n=6 112ms > 100ms(spec)  | 6Bh                | 23:19 | 0_0000b       |            |
| Reserved  | -  |                    | 30:24 | 00_00110b     | 06h        |
| Reserved  | -  |                    | 31    | 0b            |            |
| Prohibited Operations During Program Suspend                      | xxx0b: May not initiate a new erase anywhere<br>xxx1b: May not initiate a new erase in the program suspended page size<br>xx0xb: May not initiate a new page program anywhere<br>xx1xb: May not initiate a new page program in the program suspended page size<br>x0xxb: Refer to vendor datasheet for read restrictions<br>x1xxb: May not initiate a read in the program suspended page size<br>0xxxb: Additional erase or program restrictions apply<br>1xxxb: The erase and program restrictions in bits 1:0 are sufficient | 6Ch                | 3:0   | 1101b         | FDh        |
| Prohibited Operations During Erase Suspend                        | xxx0b: May not initiate a new erase anywhere<br>xxx1b: May not initiate a new erase in the erase suspended sector size<br>xx0xb: May not initiate a page program anywhere<br>xx1xb: May not initiate a page program in the erase suspended sector size<br>x0xxb: Refer to vendor datasheet for read restrictions<br>x1xxb: May not initiate a read in the erase suspended sector size<br>0xxxb: Additional erase or program restrictions apply<br>1xxxb: The erase and program restrictions in bits 5:4 are sufficient         |                    | 7:4   | 1111b         |            |
| Reserved  | -  |                    | 8     | 0b            |            |
| Program Resume to Suspend Interval                                | <64us: (count+1)*64us, count=0   | 6Dh                | 12:9  | 0000b         | 80h        |
| Suspend in-progress Program max latency                           | 40us: ((4+1)*8us=40us)   |                    | 15:13 | 10_00100b     |            |
| Erase Resume to Suspend Interval                                  | <64us: (count+1)*64us, count=0   | 6Eh                | 19:16 |               | 08h        |
| Suspend in-progress erase max latency                             | 40us: ((4+1)*8us=40us)   | 6Fh                | 23:20 | 0000b         |            |
| Suspend /resume supported   | 0=support 1=not support  |                    | 30:24 | 10_00100b     | 44h        |
|   |  |                    | 31    | 0b            |            |

# LE25S81A

Parameter Table : JDEC Basic Flash Parameter Tables (from 13th DWORD to 16th DWORD)

| Description  | Comment   | Byte Address (Hex) | Bits  | Data (Binary) | Data (Hex) |
|--|---|--------------------|-------|---------------|------------|
| Program Resume Instruction (program operation)                                       | 30h (as same as erase resume)   | 70h                | 7:0   | 0011_0000b    | 30h        |
| Program Suspend Instruction (program operation)                                      | B0h (as same as erase suspend)  | 71h                | 15:8  | 1011_0000b    | B0h        |
| Resume Instruction (write or erase type operation)                                   | 30h (as same as program resume)   | 72h                | 23:16 | 0011_0000b    | 30h        |
| Suspend Instruction (write or erase type operation)                                  | B0h (as same as program suspend)  | 73h                | 31:24 | 1011_0000b    | B0h        |
| Reserved   |   | 74h                | 1:0   | 00b           | 04h        |
| Status Register Polling Device Busy  | Use legacy polling by reading the Status Register with 05h instruction  |                    | 7:2   | 0000_01b      |            |
| Exit Deep Power down to next operation delay   | 40us: ((4+1)*8us=40us)  | 75h                | 14:8  | 10_00100b     | C4h        |
| Exit Deep Power down Instruction   | ABh   | 76h                | 15    | 1010_1011b    |            |
| Enter Deep Power down Instruction  | B9h   |                    | 22:16 | 1011_1001b    | D5h        |
| Deep Power down Supported  | 0=support 1=not support   | 77h                | 23    |               | 5Ch        |
| (4-4-4) Mode Disable Sequences   | -   | 78h                | 30:24 |               |            |
| (4-4-4) Mode Enable Sequences  | -   |                    | 31    | 0b            |            |
| (0-4-4) Mode supported   | 0=not support 1=support   | 79h                | 3:0   | 0000b         | 00h        |
| (0-4-4) Mode Exit Method   | -   |                    | 7:4   | 0000b         |            |
| (0-4-4) Mode Entry Method  | -   | 7Ah                | 8     | 0b            | 00h        |
| Quad Enable requirements (QER)   | 00b: not have a QE bit  |                    | 9     | 0b            |            |
| Hold and WP Disable  | 0: not supported  | 7Bh                | 15:10 | 00_0000b      | 00h        |
| Reserved   | -   |                    | 19:16 | 0000b         |            |
| Volatile or Non-Volatile Register and Write Enable Instruction for Status Register 1 | xxx_0xx1b: Non-Volatile Status Register 1, powers-up to last written value, use instruction 06h to enable write<br>xx1_0xxx: Status Register 1 contains a mix of volatile and non-volatile bits. The 06h instruction is used to enable writing of the register. | 7Ch                | 22:20 | 000b          | 00h        |
| Reserved   | -   |                    | 23    | 0b            |            |
| Soft Reset and Rescue Sequence Support   | Issue reset enable instruction 66h, and then issue reset instruction 99h.   | 7Dh                | 31:24 | 0000_0000b    | 00h        |
| Exit 4-Byte Addressing   |   | 7Eh                | 6:0   | 001_1001b     | 19h        |
| Enter 4-Byte Addressing  |   |                    | 7     | 0b            |            |
| Exit 4-Byte Addressing   |   | 7Dh                | 13:8  | 01_0000b      | 10h        |
| Enter 4-Byte Addressing  |   |                    | 15:14 | 00b           |            |
| Exit 4-Byte Addressing   |   | 7Eh                | 23:16 | 0000_0000b    | 00h        |
| Enter 4-Byte Addressing  |   | 7Fh                | 31:24 | 0000_0000b    | 00h        |

# LE25S81A

Parameter Table : Vender(ON Semiconductor) Parameter 1 Tables (from 1th DWORD to 4th DWORD)

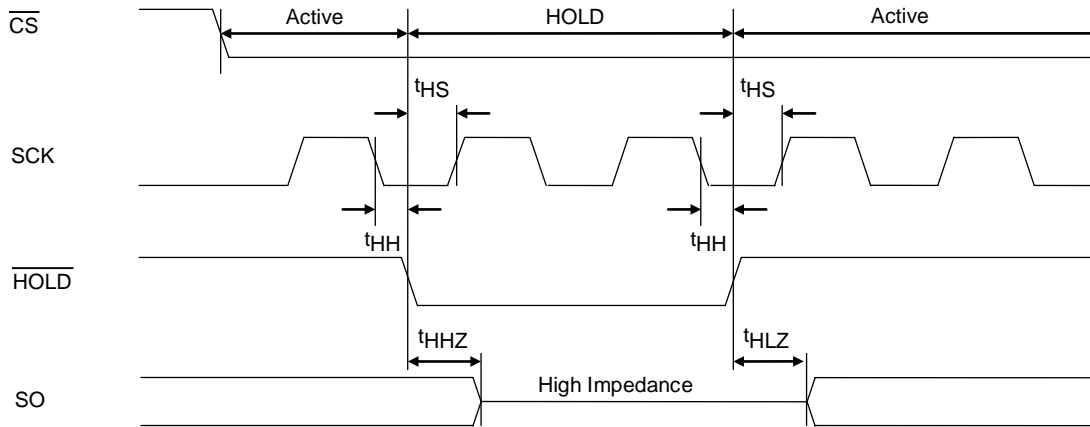
| Description                              | Comment  | Byte Address (Hex) | Bits  | Data (Binary)                          | Data (Hex)        |
|--|--|--------------------|-------|--|-------------------|
|  |  |                    |       |  | LE25S81A          |
| Supply Maximum Voltage                   | 1900h=1.900V    2400h=2.400V<br>1950h=1.950V    2700h=2.700V<br>2000h=2.000V    3000h=3.000V<br>2200h=2.200V    3600h=3.600V | C0h<br>C1h         | 15:0  | -                                      | 00h<br>24h        |
| Supply Minimum Voltage                   | 1600h=1.600V    2000h=2.000V<br>1650h=1.650V    2200h=2.200V<br>1700h=1.700V    2300h=2.300V<br>1800h=1.800V    2700h=2.700V | C2h<br>C3h         | 31:16 | -                                      | 50h<br>16h        |
| RESET Pin                                | 0=not support<br>1= support  | C4h                | 0     | 0b                                     | 14h               |
| RESET Active Logic Level                 | 0=active logic is 0<br>1=active logic is 1   |                    | 1     | 0b                                     |                   |
| HOLD Pin                                 | 0=not support<br>1= support  |                    | 2     | 1b                                     |                   |
| HOLD Active Logic Level                  | 0=active logic is 0<br>1=active logic is 1   |                    | 3     | 0b                                     |                   |
| WP Pin                                   | 0=not support<br>1= support  |                    | 4     | 1b                                     |                   |
| WP Active Logic Level                    | 0=active logic is 0<br>1=active logic is 1   |                    | 5     | 0b                                     |                   |
| Reserved                                 | 00b  |                    | 7:6   | 00b                                    |                   |
| Reserved                                 | All FFh  | C5h<br>C6h<br>C7h  | 31:8  | 1111_1111b<br>1111_1111b<br>1111_1111b | FFh<br>FFh<br>FFh |
| JDEC ID Operation code                   | 9Fh  | C8h                | 7:0   | 1001_1111b                             | 9Fh               |
| JDEC ID Read Data (Manufacture code)     | 62h (ON Semiconductor)   | C9h                | 15:8  | 0110_0010b                             | 62h               |
| JDEC ID Read Data (Memory type)          | 16h  | CAh                | 23:16 | 0001_0110b                             | 16h               |
| JDEC ID Read Data (Memory capacity code) | 14h (8M bits)  | CBh                | 31:24 | 0001_0100b                             | 14h               |
| Device ID Operation code                 | ABh  | CCh                | 7:0   | 1010_1011b                             | ABh               |
| Device ID Read Data                      | 87h(LE25S81A)  | CDh                | 15:8  | 1000_0111b                             | 87h               |
| Reserved                                 | All FFh  | CEh<br>CFh         | 31:16 | 1111_1111b<br>1111_1111b               | FFh<br>FFh        |



## 11. Hold Function

Using the  $\overline{\text{HOLD}}$  pin, the hold function suspends serial communication (it places it in the hold status). "Figure 24. HOLD Function" shows the timing waveforms. The device is placed in the hold status at the falling  $\overline{\text{HOLD}}$  edge while the logic level of  $\text{SCK}$  is low, and it exits from the hold status at the rising  $\overline{\text{HOLD}}$  edge. When the logic level of  $\text{SCK}$  is high,  $\overline{\text{HOLD}}$  must not rise or fall. The hold function takes effect when the logic level of  $\text{CS}$  is low, the hold status is exited and serial communication is reset at the rising  $\overline{\text{CS}}$  edge. In the hold status, the  $\text{SO}$  output is in the high-impedance state, and  $\text{SI}$  and  $\text{SCK}$  are "don't care".

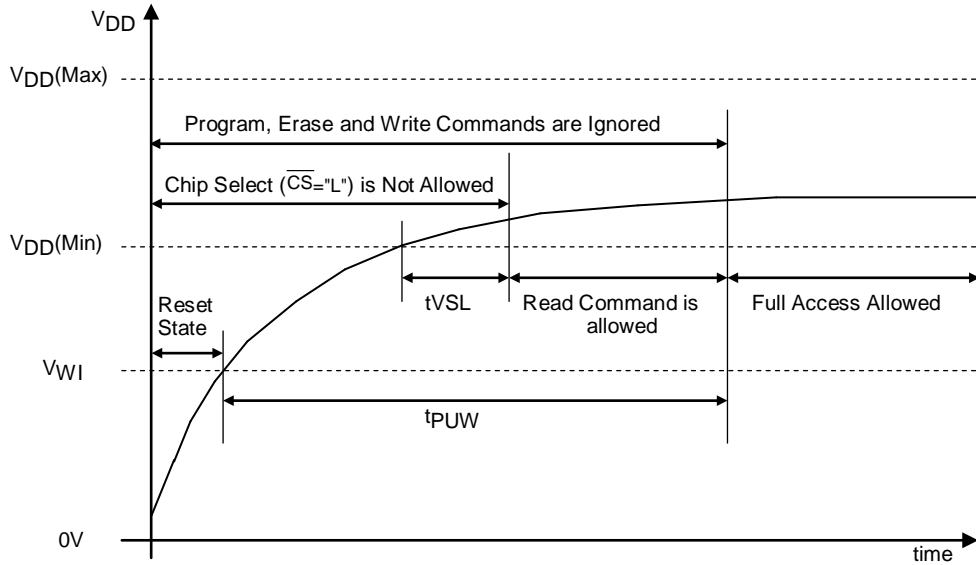
Figure 24. HOLD Function



## 12. Power-on

In order to protect against unintentional writing,  $\overline{CS}$  must be within at  $V_{DD}-0.3$  to  $V_{DD}+0.3$  on power-on. After power-on, the supply voltage has stabilized at  $V_{DD}$  (min) or higher, and waits for  $t_{VSL}$  before  $\overline{CS}$  is driven to "Low". The device is in the standby state after power is turned on.

Figure 25. Power-on Timing



### Power-up timing

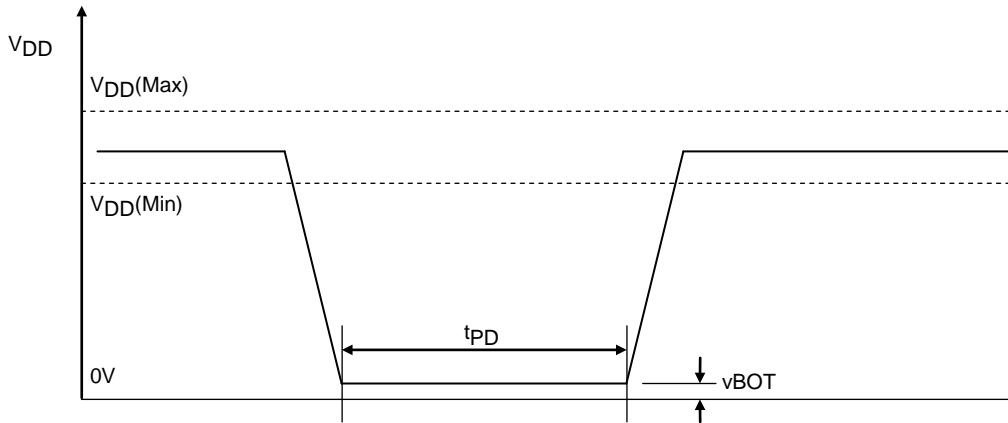
| Parameter                                   | Symbol    | spec |     | unit          |
|---|-----------|------|-----|---------------|
|   |           | min  | max |               |
| $V_{DD}(\text{Min})$ to $\overline{CS}$ Low | $t_{VSL}$ | 300  |     | $\mu\text{s}$ |
| Time to Write Operation                     | $t_{PUW}$ | 100  | 500 | $\mu\text{s}$ |
| Operation Inhibit Voltage                   | $V_{WI}$  | 1.0  | 1.5 | V             |

### 13. Hardware Data Protection

LE25S81A incorporates a power-on reset function. The following conditions must be met in order to ensure that the power reset circuit will operate stably.

No guarantees are given for data in the event of an instantaneous power failure occurring during the writing period.

**Figure 26. Power-down Timing**



**Power-down timing**

| Parameter          | Symbol    | spec |     | unit |
|--------------------|-----------|------|-----|------|
|                    |           | min  | max |      |
| power-down time    | $t_{PD}$  | 10   |     | ms   |
| power-down voltage | $V_{BOT}$ |      | 0.2 | V    |

### 14. Software Data Protection

The LE25S81A eliminates the possibility of unintentional operations by not recognizing commands under the following conditions.

- When a write command is input and the rising  $\overline{CS}$  edge timing is not in a byte cycle (8 CLK units of SCK)
- When the Page Program data is not in 1-byte increments
- When the Write Status Register command is input for 2 bytes cycles or more

### 15. Decoupling Capacitor

0.1 $\mu$ F ceramic capacitor must be provided to each device and connected between  $V_{DD}$  and  $V_{SS}$  in order to ensure that the device will operate stably.

## 16. Specifications

### 16-1. Absolute Maximum Ratings

| Parameter              | Symbol | Conditions               | Ratings              | unit |
|------------------------|--------|--------------------------|----------------------|------|
| Maximum supply voltage |        | With respect to $V_{SS}$ | -0.5 to +2.9         | V    |
| DC voltage (all pins)  |        | With respect to $V_{SS}$ | -0.5 to $V_{DD}+0.5$ | V    |
| Storage temperature    | Tstg   |                          | -55 to +150          | °C   |

Stresses exceeding those listed in the Maximum Ratings table may damage the device. If any of these limits are exceeded, device functionality should not be assumed, damage may occur and reliability may be affected.

### 16-2. Operating Conditions

| Parameter                     | Symbol | Conditions | Ratings      | unit |
|-------------------------------|--------|------------|--------------|------|
| Operating supply voltage      |        |            | 1.65 to 2.40 | V    |
| Operating ambient temperature |        |            | -40 to +90   | °C   |

Functional operation above the stresses listed in the Recommended Operating Ranges is not implied. Extended exposure to stresses beyond the Recommended Operating Ranges limits may affect device reliability.

### 16-3. Data retention, Rewriting cycles

| Parameter      | Symbol | condition             | min     | max | unit              |
|----------------|--------|-----------------------|---------|-----|-------------------|
| Rewrite Cycles | cycRW  | Status resister write | 1,000   |     | cycles/<br>Sector |
|                |        | Program/Erase         | 100,000 |     |                   |
| Data retention | tDRET  |                       | 20      |     | year              |

### 16-4. Pin Capacitance at $T_a=25^\circ\text{C}$ , $f=1\text{MHz}$

| Parameter              | Symbol   | Conditions  | Ratings | unit |
|------------------------|----------|-------------|---------|------|
|                        |          |             | max     |      |
| Output pin capacitance | $C_{SO}$ | $V_{SO}=0V$ | 12      | pF   |
| Input pin Capacitance  | $C_{IN}$ | $V_{IN}=0V$ | 6       | pF   |

Note: These parameter values do not represent the results of measurements undertaken for all devices but rather values for some of the sampled devices.

### 16-5. AC Test Conditions

Input pulse level .....  $0.2V_{DD}$  to  $0.8V_{DD}$

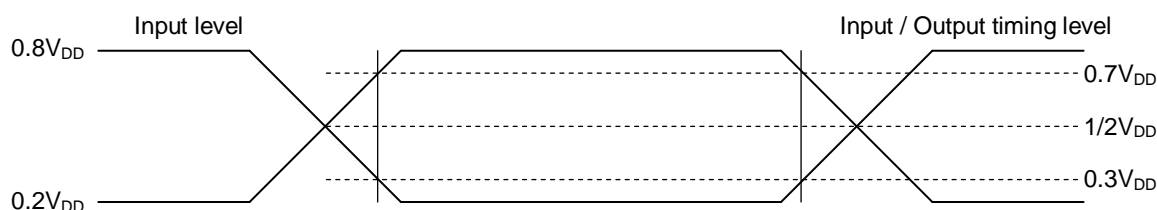
Input rising/falling time .. 5ns

Input timing level .....  $0.3V_{DD}$ ,  $0.7V_{DD}$

Output timing level .....  $1/2 \times V_{DD}$

Output load..... 15pF

Note: As the test conditions for "typ", the measurements are conducted using 1.8V for  $V_{DD}$  at room temperature.



# LE25S81A

## 16-6. DC Characteristics

| Parameter                                | Symbol             | Conditions  |   |       | V <sub>DD</sub> =1.65 to 1.90V |     |                      | V <sub>DD</sub> =1.65 to 2.40V |                      |                      | unit |
|--|--------------------|---|---|-------|--------------------------------|-----|----------------------|--------------------------------|----------------------|----------------------|------|
|  |                    |   |   |       | Ratings                        |     |                      | Ratings                        |                      |                      |      |
|  |                    |   |   |       | min                            | typ | max                  | min                            | typ                  | max                  |      |
| Read mode operating current              | I <sub>CCR</sub>   | SCK=0.1V <sub>DD</sub> /0.9V <sub>DD</sub> ,<br>HOLD=WP=0.9V <sub>DD</sub> ,<br>SO=open       | Low-Power Read (RDLP: 03h)                                | 33MHz |                                | 3.0 | 3.5                  |                                | 4.0                  | 5.0                  | mA   |
|  |                    |   |   | 40MHz |                                | 3.5 | 4.5                  |                                | 4.5                  | 5.5                  | mA   |
|  |                    |   | High-Speed Read (RDHS: 0Bh)                               | 50MHz |                                | 4.0 | 5.0                  |                                | 5.0                  | 6.0                  | mA   |
|  |                    |   |   | 70MHz |                                | 5.0 | 6.0                  |                                | 6.0                  | 7.0                  | mA   |
|  |                    |   | Dual Output Read (RDDO: 3Bh) or Dual I/O Read (RDIO: 8Bh) | 33MHz |                                | 4.0 | 5.0                  |                                | 5.5                  | 7.0                  | mA   |
|  |                    |   |   | 50MHz |                                | 5.0 | 6.0                  |                                | 6.5                  | 8.0                  | mA   |
|  |                    |   | 66MHz   |       | 5.5                            | 6.5 |                      | 7.5                            | 8.5                  | mA                   |      |
| Small Sector Erase operating current     | I <sub>CCSSE</sub> | t <sub>SSE</sub> =max, Average current  |   |       |                                | 3.5 | 4.5                  |                                | 4.0                  | 5.0                  | mA   |
| Sector Erase operating current           | I <sub>CCSE</sub>  | t <sub>SE</sub> =max, Average current   |   |       |                                | 3.5 | 4.5                  |                                | 4.0                  | 5.0                  | mA   |
| Chip Erase operating current             | I <sub>CCCHE</sub> | t <sub>CHE</sub> =max, Average current  |   |       |                                | 4.0 | 5.0                  |                                | 4.5                  | 5.5                  | mA   |
| Normal Program mode operating current    | I <sub>CCPP</sub>  | t <sub>pp</sub> =max, Average current   |   |       |                                | 6.5 | 7.5                  |                                | 7.0                  | 8.0                  | mA   |
| Low-Power Program mode operating current | I <sub>CCPPL</sub> | t <sub>pPL</sub> =max, Average current  |   |       |                                | 5.0 | 6.5                  |                                | 5.5                  | 7.0                  | mA   |
| CMOS standby current                     | I <sub>SB</sub>    | CS=V <sub>DD</sub> , HOLD=WP=V <sub>DD</sub> , SI=V <sub>SS</sub> /V <sub>DD</sub> , SO=open, |   |       |                                | 9   | 50                   |                                | 10                   | 55                   | μA   |
| Deep Power-down standby current          | I <sub>DSB</sub>   | CS=V <sub>DD</sub> , HOLD=WP=V <sub>DD</sub> , SI=V <sub>SS</sub> /V <sub>DD</sub> , SO=open, |   |       |                                | 3.0 | 12                   |                                | 4.0                  | 15                   | μA   |
| Input leakage current                    | I <sub>LI</sub>    |   |   |       |                                |     | 2.0                  |                                |                      | 2.0                  | μA   |
| Output leakage current                   | I <sub>LO</sub>    |   |   |       |                                |     | 2.0                  |                                |                      | 2.0                  | μA   |
| Input low voltage                        | V <sub>IL</sub>    |   |   |       | -0.3                           |     | 0.3V <sub>DD</sub>   |                                | -0.3                 | 0.3V <sub>DD</sub>   | V    |
| Input high voltage                       | V <sub>IH</sub>    |   |   |       | 0.7V <sub>DD</sub>             |     | V <sub>DD</sub> +0.3 |                                | 0.7V <sub>DD</sub>   | V <sub>DD</sub> +0.3 | V    |
| Output low voltage                       | V <sub>OL</sub>    | I <sub>OL</sub> =100μA, V <sub>DD</sub> =V <sub>DD</sub> min                                  |   |       |                                |     | 0.2                  |                                |                      | 0.2                  | V    |
|  |                    | I <sub>OL</sub> =1.6mA, V <sub>DD</sub> =V <sub>DD</sub> min                                  |   |       |                                |     | 0.4                  |                                |                      | 0.4                  | V    |
| Output high voltage                      | V <sub>OH</sub>    | I <sub>OH</sub> =-100μA, V <sub>DD</sub> =V <sub>DD</sub> min                                 |   |       | V <sub>DD</sub> -0.2           |     |                      |                                | V <sub>DD</sub> -0.2 |                      | V    |

Product parametric performance is indicated in the Electrical Characteristics for the listed test conditions, unless otherwise noted. Product performance may not be indicated by the Electrical Characteristics if operated under different conditions.

## 16-7. AC Characteristics

| Parameter                             |                                 | Symbol            | Ratings |                        |                     | unit |
|---------------------------------------|---------------------------------|-------------------|---------|------------------------|---------------------|------|
|                                       |                                 |                   | min     | typ                    | max                 |      |
| Clock frequency                       | Low-Power Read<br>(RDLP: 03h)   | f <sub>CLK</sub>  |         |                        | 40                  | MHz  |
|                                       | Dual Output Read<br>(RDDO: 3Bh) |                   |         |                        | 66                  |      |
|                                       | Dual I/O Read<br>(RDIO: BBh)    |                   |         |                        | 70                  |      |
| Other instructions                    |                                 |                   |         |                        | 70                  |      |
| Input signal rising/falling time      |                                 | t <sub>RF</sub>   | 0.1     |                        |                     | V/ns |
| SCK logic high level pulse width      | 33MHz                           | t <sub>CLHI</sub> | 12      |                        |                     | ns   |
|                                       | 40MHz                           |                   | 11      |                        |                     |      |
|                                       | 66MHz                           |                   | 6       |                        |                     |      |
|                                       | 70MHz                           |                   | 6       |                        |                     |      |
| SCK logic low level pulse width       | 33MHz                           | t <sub>CLLO</sub> | 12      |                        |                     | ns   |
|                                       | 40MHz                           |                   | 11      |                        |                     |      |
|                                       | 66MHz                           |                   | 6       |                        |                     |      |
|                                       | 70MHz                           |                   | 6       |                        |                     |      |
| CS active setup time                  |                                 | t <sub>SLCH</sub> | 8       |                        |                     | ns   |
| CS not active hold time               |                                 | t <sub>CHSL</sub> | 3       |                        |                     | ns   |
| Data setup time                       |                                 | t <sub>DS</sub>   | 3       |                        |                     | ns   |
| Data hold time                        |                                 | t <sub>DH</sub>   | 3       |                        |                     | ns   |
| CS wait pulse width                   |                                 | t <sub>CPH</sub>  | 20      |                        |                     | ns   |
| CS active hold time                   |                                 | t <sub>CHSH</sub> | 8       |                        |                     | ns   |
| CS not active setup time              |                                 | t <sub>SHCH</sub> | 3       |                        |                     | ns   |
| Output high impedance time from CS    |                                 | t <sub>CHZ</sub>  |         |                        | 8                   | ns   |
| Output data time from SCK             |                                 | t <sub>v</sub>    |         |                        | 8                   | ns   |
| Output data hold time                 |                                 | t <sub>HO</sub>   | 1       |                        |                     | ns   |
| Output low impedance time from SCK    |                                 | t <sub>CLZ</sub>  | 0       |                        |                     | ns   |
| HOLD setup time                       |                                 | t <sub>HS</sub>   | 6       |                        |                     | ns   |
| HOLD hold time                        |                                 | t <sub>HH</sub>   | 6       |                        |                     | ns   |
| Output low impedance time from HOLD   |                                 | t <sub>HLZ</sub>  |         |                        | 10                  | ns   |
| Output high impedance time from HOLD  |                                 | t <sub>HHZ</sub>  |         |                        | 10                  | ns   |
| WP setup time                         |                                 | t <sub>WPS</sub>  | 20      |                        |                     | ns   |
| WP hold time                          |                                 | t <sub>WPH</sub>  | 20      |                        |                     | ns   |
| Write status register time            |                                 | t <sub>WRSR</sub> |         | 5                      | 8                   | ms   |
| Normal Page Programming cycle time    | 256Byte                         | t <sub>PP</sub>   |         | 0.30                   | 0.50                | ms   |
|                                       | nByte                           |                   |         | 0.14 +<br>n * 0.16/256 | 0.35 + n * 0.15/256 |      |
| Low-Power Page Programming cycle time | 256Byte                         | t <sub>PPL</sub>  |         | 0.45                   | 1.00                | ms   |
|                                       | nByte                           |                   |         | 0.14 +<br>n * 0.31/256 | 0.50 + n * 0.50/256 |      |
| Small Sector Erase cycle time         |                                 | t <sub>SSE</sub>  |         | 10                     | 130                 | ms   |
| Sector Erase cycle time               |                                 | t <sub>SE</sub>   |         | 15                     | 180                 | ms   |
| Chip Erase cycle time                 |                                 | t <sub>CHE</sub>  |         | 120                    | 1500                | ms   |
| Recovery time from suspend            |                                 | t <sub>RSUS</sub> |         |                        | 40                  | μs   |
| Deep Power-down time                  |                                 | t <sub>DP</sub>   |         |                        | 5                   | μs   |
| Deep Power-down recovery time         |                                 | t <sub>RDP</sub>  |         |                        | 40                  | μs   |
| Internal reset time                   |                                 | t <sub>RST</sub>  |         |                        | 40                  | μs   |

Product parametric performance is indicated in the Electrical Characteristics for the listed test conditions, unless otherwise noted. Product performance may not be indicated by the Electrical Characteristics if operated under different conditions.

17. Timing waveforms

Figure 27. Serial Input Timing

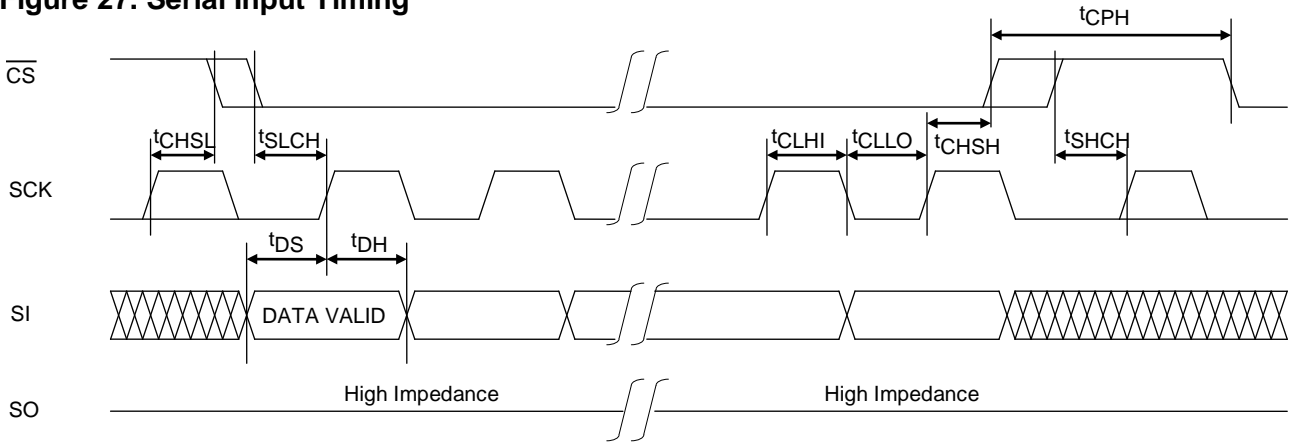


Figure 28. Serial Output Timing

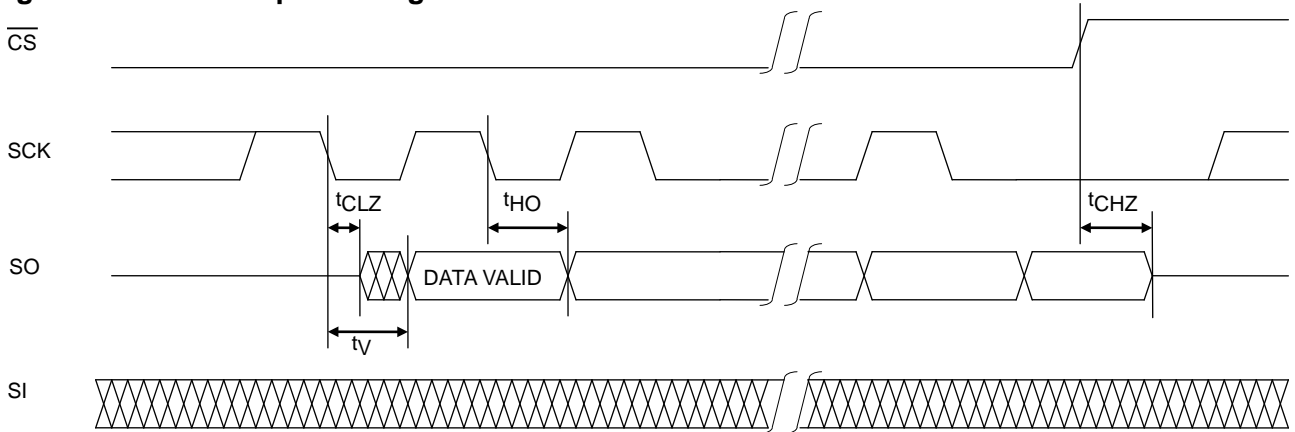


Figure 29. Hold Timing

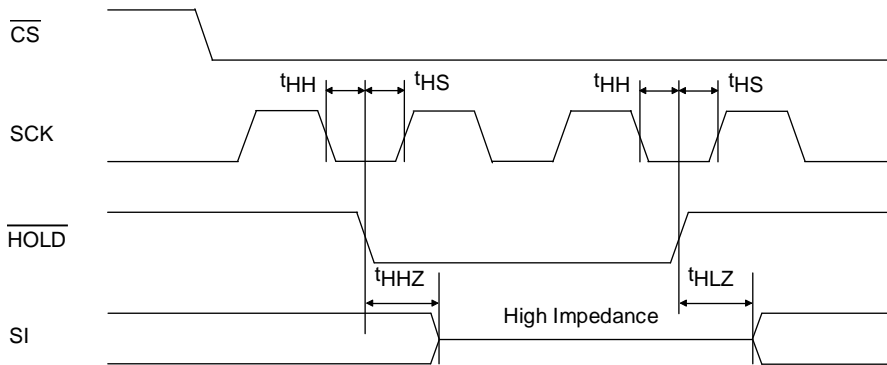


Figure 30. Status Register Write Timing

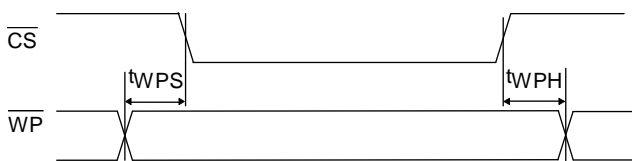
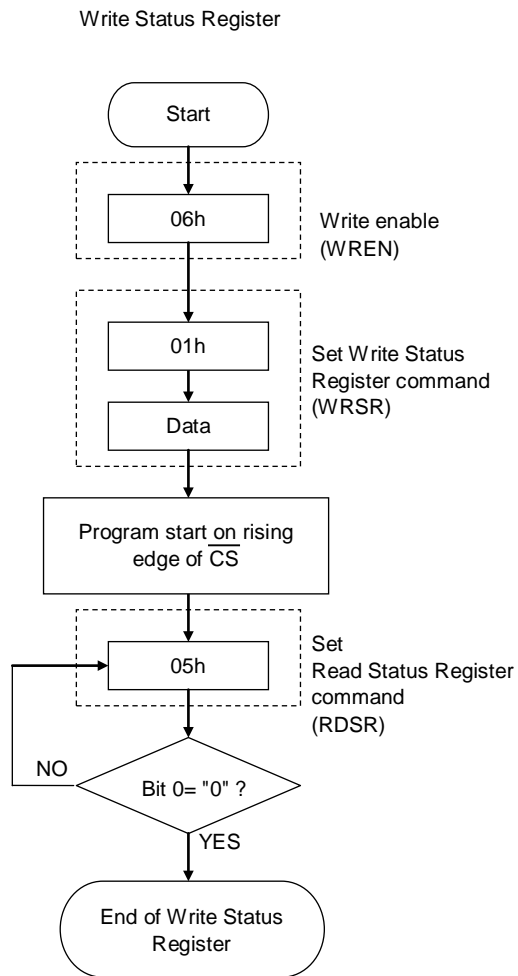


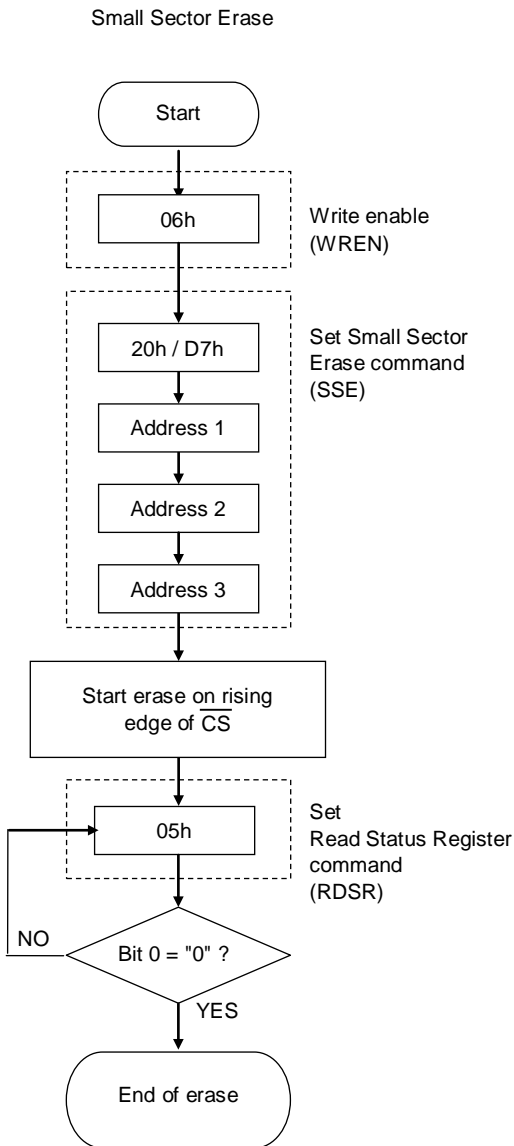
Figure 31. Write Status Register Flowcharts



\* Automatically placed in write disabled state at the end of the Write Status Register

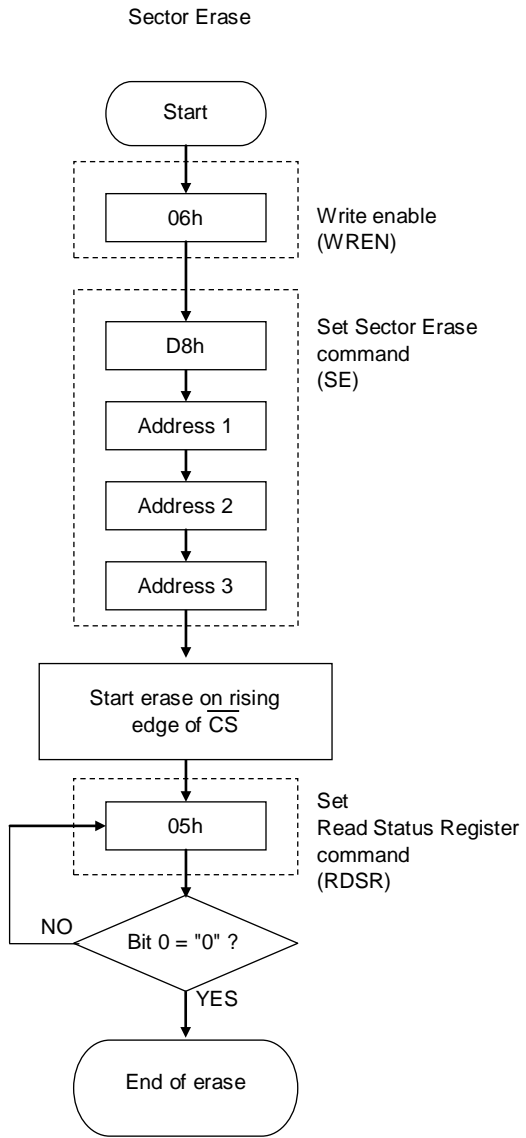


Figure 32. Small Sector Erase Flowcharts



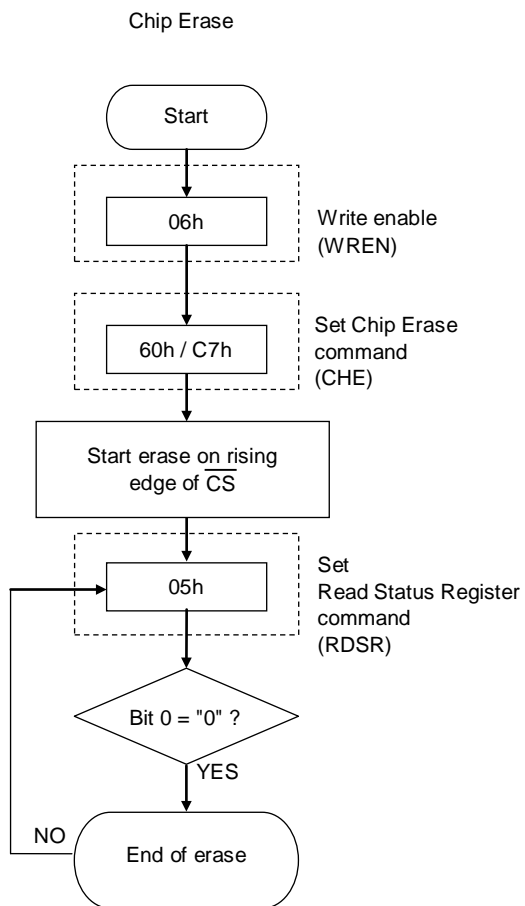
\* Automatically placed in write disabled state at the end of the erase

Figure 33. Sector Erase Flowcharts



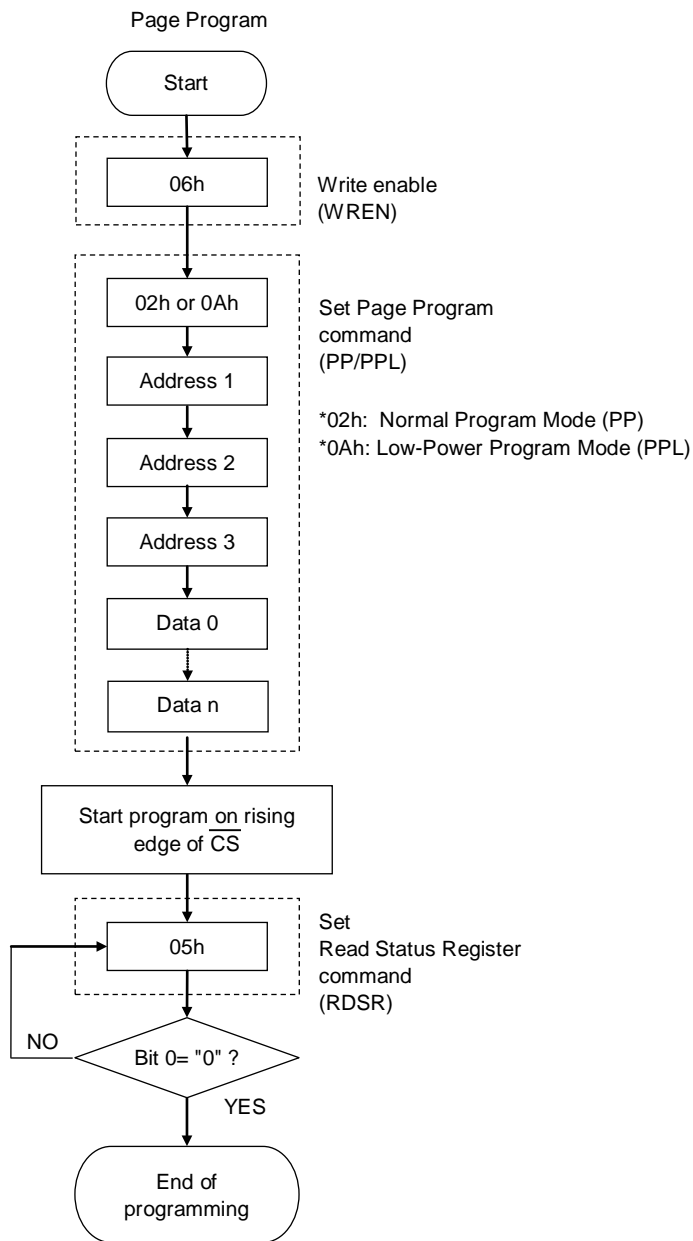
\* Automatically placed in write disabled state at the end of the erase

Figure 34. Chip Erase Flowcharts



\* Automatically placed in write disabled state at the end of the erase

Figure 35. Page Program Flowcharts



\* Automatically placed in write disabled state at the end of the programming operation.

# LE25S81A

## ORDERING INFORMATION

| Device           | Package   | Shipping (Qty / Packing) |
|------------------|---|--------------------------|
| LE25S81AMDTWG    | SOIC8, 150mils<br>(Pb-Free / Halogen Free)                  | 2500 / Tape & Reel       |
| LE25S81AFDTWG    | VSOIC8 NB<br>(Pb-Free / Halogen Free)                       | 3000 / Tape & Reel       |
| LE25S81AQE (TBD) | VDFN8 5x6, 1.27P / VSON8T (6x5)<br>(Pb-Free / Halogen Free) | TBD / Tape & Reel        |

† For information on tape and reel specifications, including part orientation and tape sizes, please refer to our Tape and Reel Packaging Specifications Brochure, BRD8011/D. [http://www.onsemi.com/pub\\_link/Collateral/BRD8011-D.PDF](http://www.onsemi.com/pub_link/Collateral/BRD8011-D.PDF)

ON Semiconductor and the ON logo are registered trademarks of Semiconductor Components Industries, LLC (SCILLC) or its subsidiaries in the United States and/or other countries. SCILLC owns the rights to a number of patents, trademarks, copyrights, trade secrets, and other intellectual property. A listing of SCILLC's product/patent coverage may be accessed at [www.onsemi.com/site/pdf/Patent-Marking.pdf](http://www.onsemi.com/site/pdf/Patent-Marking.pdf). SCILLC reserves the right to make changes without further notice to any products herein. SCILLC makes no warranty, representation or guarantee regarding the suitability of its products for any particular purpose, nor does SCILLC assume any liability arising out of the application or use of any product or circuit, and specifically disclaims any and all liability, including without limitation special, consequential or incidental damages. "Typical" parameters which may be provided in SCILLC data sheets and/or specifications can and do vary in different applications and actual performance may vary over time. All operating parameters, including "Typicals" must be validated for each customer application by customer's technical experts. SCILLC does not convey any license under its patent rights nor the rights of others. SCILLC products are not designed, intended, or authorized for use as components in systems intended for surgical implant into the body, or other applications intended to support or sustain life, or for any other application in which the failure of the SCILLC product could create a situation where personal injury or death may occur. Should Buyer purchase or use SCILLC products for any such unintended or unauthorized application, Buyer shall indemnify and hold SCILLC and its officers, employees, subsidiaries, affiliates, and distributors harmless against all claims, costs, damages, and expenses, and reasonable attorney fees arising out of, directly or indirectly, any claim of personal injury or death associated with such unintended or unauthorized use, even if such claim alleges that SCILLC was negligent regarding the design or manufacture of the part. SCILLC is an Equal Opportunity/Affirmative Action Employer. This literature is subject to all applicable copyright laws and is not for resale in any manner.